

37° Flared SAE - J514

Tube Fittings with O-Ring for Fractional and Metric

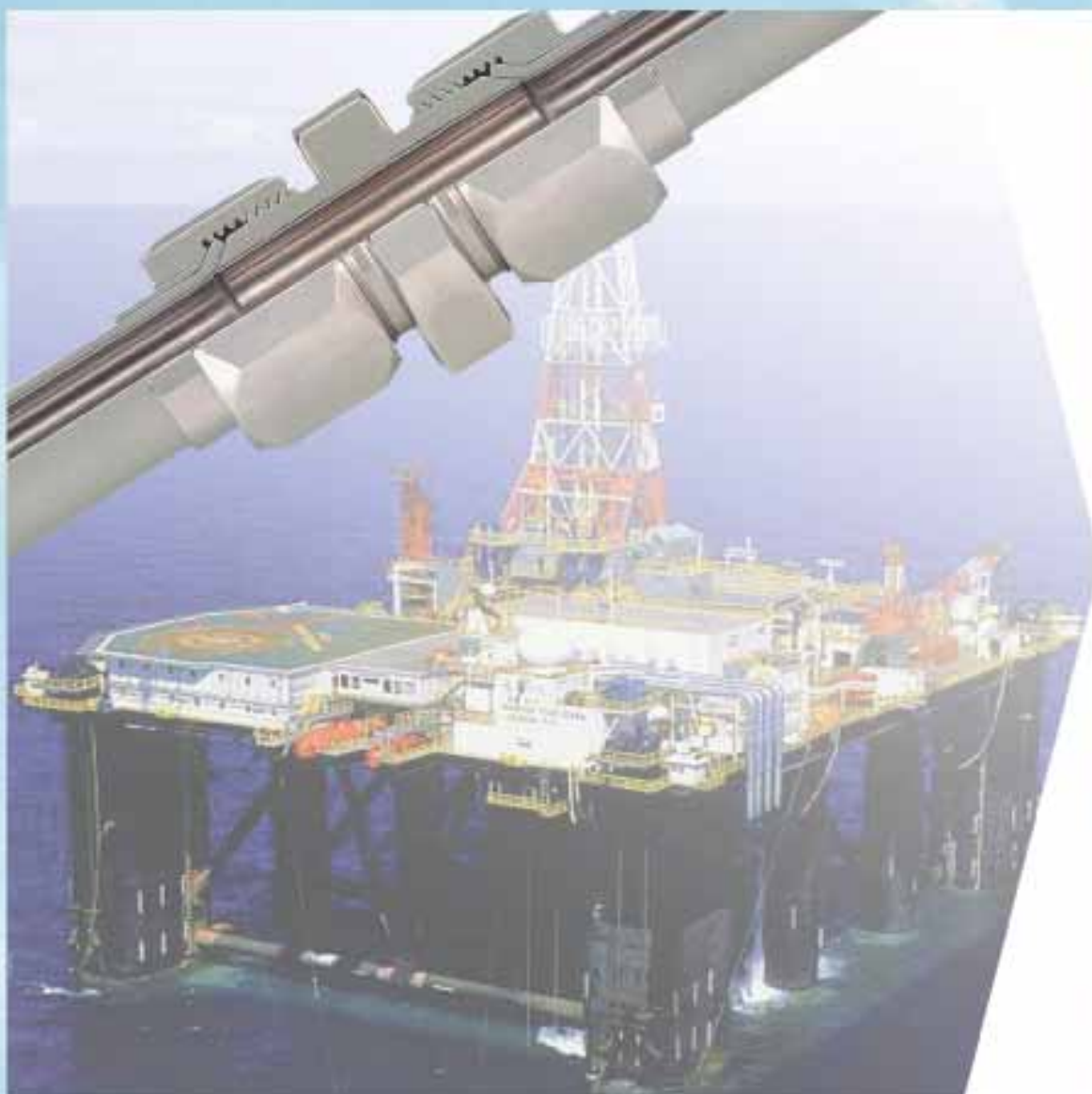

HY-LOK CORPORATION



По вопросам продаж и поддержки обращайтесь:

Волгоград +7 (8442) 45-94-42
Екатеринбург +7 (343) 302-14-75
Ижевск +7 (3412) 20-90-75
Казань +7 (843) 207-19-05

Краснодар +7 (861) 238-86-59
Красноярск +7 (391) 989-82-67
Москва +7 (499) 404-24-72
Ниж.Новгород +7 (831) 200-34-65

Новосибирск +7 (383) 235-95-48
Омск +7 (381) 299-16-70
Пермь +7 (342) 233-81-65
Ростов-на-Дону +7 (863) 309-14-65

Самара +7 (846) 219-28-25
Санкт-Петербург +7 (812) 660-57-09
Саратов +7 (845) 239-86-35
Сочи +7 (862) 279-22-65

сайт: hylok.pro-solution.ru | эл. почта: hky@pro-solution.ru
телефон: 8 800 511 88 70

Index

	Union FU	16		Branch Tee FBTM	28		O-Ring Seal Swivel Connector (UNF) FSFOM	41
	Union Elbow FL	17		45° Male Elbow FLMB	29		Swivel Female Connector FSFFC	42
	Union Tee FT	18		Female Connector FFC	30		Swivel Elbow FSL	43
	Union Cross FC	19		Female Elbow FLF	31		Swivel Run Tee FSRT	44
	Bulkhead Union FBU	20		Female Run Tee FRTF	32		Swivel Branch Tee FSBT	45
	Weld Bulkhead Union FBW	21		Female Branch Tee FBTF	33		Nut FN	46
	Female Bulkhead Union FBFC	22		O-Ring Seal Male Connector (PF) FOMR	34		Sleeve FS	46
	Bulkhead Union Elbow FBL	23		O-Ring Seal Male Connector (UNF) FOM	35		Plug FP	47
	Female Bulkhead Union FBFC	24		O-Ring Seal Male Elbow (UNF) FOLM	36		Plug Cap FPC	47
	Male Connector FMC	25		O-Ring Seal 45° Male Elbow (UNF) FOLMB	37		Tube End Reducer FTER	48
	Male Elbow FLM	26		O-Ring Seal Branch Tee (UNF) FOBTM	38		Bulkhead Lock Nut FLN	48
	Male Run Tee FRTM	27		O-Ring Seal Run Tee (UNF) FORTM	38			
				Swivel Connector FSFMC	40			

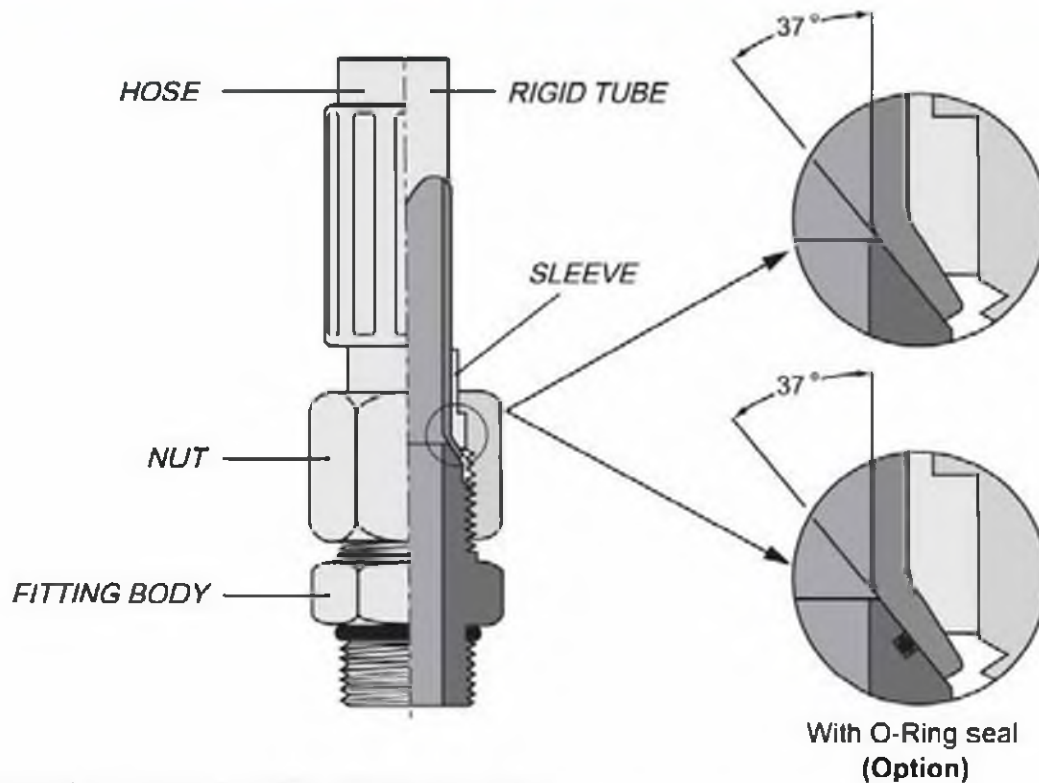

This type of assembly ensures very high dependability.

The assembly is achieved by connecting the two parts together by means of a nut and a sleeve.

MAIN CHARACTERISTICS

- The assembly performs extremely well even under severe vibrations, pressure bursts, and thermal shocks.
- On tightening, the sleeve ensures tube alignment with fitting axis, reduces mechanical strain on tube and decreases vibrations.
- Fitting can be equally coupled to metric or inch-tubes.
- The tube doesn't undergo distortion, remains constant and fluid pressure losses are negligible.
- The system efficiency remains equally guaranteed after several disassemblies and assembly operations and individual replacement of any component.

MATERIAL AND SURFACE PROTECTION

Fittings are normally made of steel and obtained from controlled bar-stock machining (straight fittings, nuts) or by hot or cold forming (shaped fittings, sleeves). Alternative materials such as brass, aluminium, stainless steel available upon request. All carbon steel fittings but those to be brazed or welded-on tubes, are yellow zinc plated to a Min. thickness of 0.008 mm to comply with ASTM-B-117, UNI 5687 hot salt spray test method. All threads are shock protected with plastic caps or plugs.

SEALS

All fittings requiring seals are supplied with O-Ring seals and washers.

FLARING OPERATION

Tube flaring is carried out in two different ways ; single wall flare on thick wall tubes and double wall flare on thin wall tubes to reinforce same. Refer to table I and II for recommended values.

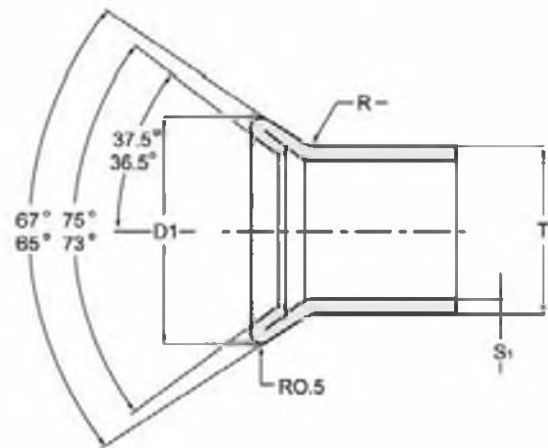
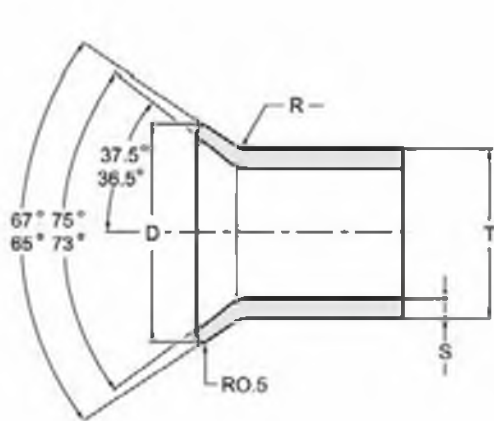

TABLE I - Metric tubes.

T Tube O.D	D		S	D1		S1	R
	Max.	Min.		Max.	Min.		
6	9.2	8.4	1.5	9.2	8.4	0.88	0.8
8	10.8	10.1	1.5	10.8	10.1	0.88	0.8
10	12.5	12	1.5	12.5	12.0	1.2	1.0
12	16.7	16	2.0	16.7	16.0	1.2	1.5
14	19.5	18.8	2.0	19.5	18.8	1.2	1.6
15	20.0	19.4	2.0	20.0	19.4	1.2	1.5
16	20.0	19.4	2.5	20.0	19.4	1.2	1.5
18	24.0	23.5	2.5	24.0	23.5	1.2	2.0
20	24.5	24.0	2.5	24.5	24.0	1.5	2.0
22	27.2	26.2	3.0	27.2	26.2	1.5	2.0
25	30.2	29.5	3.0	30.2	29.5	1.5	2.3
30	38.0	37.4	3.0	38.0	37.4	1.5	2.3
32	38.3	37.6	3.0	38.3	37.6	1.5	2.3
38	44.5	43.5	4.0	44.5	43.5	1.5	2.8

TABLE II - Inch tubes

T Tube O.D	D		S	D1		S1	R
	Max.	Min.		Max.	Min.		
1/4	9.1	8.6	1.6	9.1	8.6	0.8	0.8
5/16	10.9	10.2	1.6	10.9	10.2	0.8	0.8
3/8	12.4	11.8	1.8	12.4	11.6	1.2	1.0
1/2	16.7	16.0	2.1	16.7	16.0	1.2	1.5
5/8	20.0	19.3	2.4	20.0	19.3	1.2	1.5
3/4	24.1	23.3	2.7	24.1	23.3	1.2	2.0
7/8	27.1	26.4	2.7	27.1	26.4	1.6	2.0
1"	30.4	29.7	3.0	30.4	29.7	1.6	2.2
1 1/4	38.3	37.5	3.0	38.3	37.5	1.6	2.2
1 1/2	44.4	43.1	4.0	44.4	43.1	1.6	2.7

CONDITION FOR A CORRECT FLARING

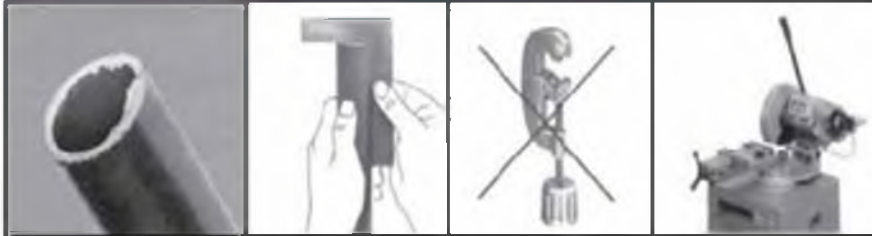

1.0 Sawing process

- 1.1 Saw the tube at light angle. An angular offset of 0.5° in relation to the tube axis is permissible.
- 1.2 Do not use a tube cutter because this would cause formation of considerable burrs and an angular cut. Use sawing machine or device instead.

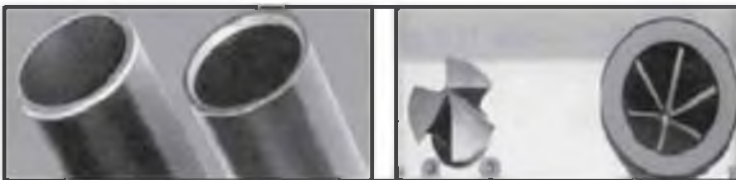

2.0 Deburring process

- 2.1 After clean the tube, lightly deburr tube ends at the inside and outside edge.

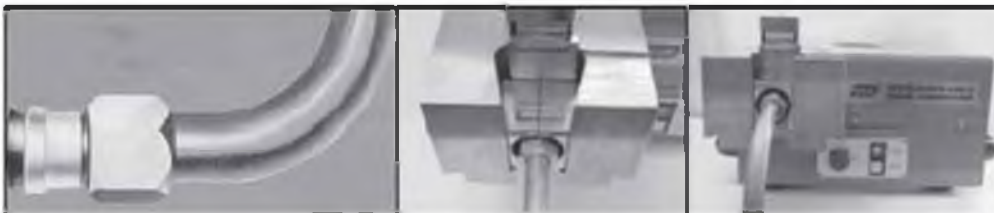

3.0 Flaring process

- 3.1 Set the pressure in accordance with table.
- 3.2 Oil the flaring cone.
- 3.3 Insert the clamping grips corresponding to each outside diameter of the tube to the flaring device.
- 3.4 Slide the nut and sleeve onto the tube.
- 3.5 Insert the tube through the clamping grips up to the stopper and press against it.
- 3.6 Start with the flaring process.
- 3.7 Remove the flared tube including the clamping grips from the flaring device.

ATTENTION

The flare collar has to be square and concentric to the tube as well as to the flared body of 37°
 Unequal flarings point to either defect tools or to manual operating mistakes.
 The inside cone of the tube has to be clean, in case the surface is faulty, it has to be polished with a polishing mandrel.

ASSEMBLY INSTRUCTIONS.

On the table below are shown the basic dimensions to calculate the overall length of tube assemblies, the actual dimension of fittings when assembled, the recommended assembly torques and working pressures.

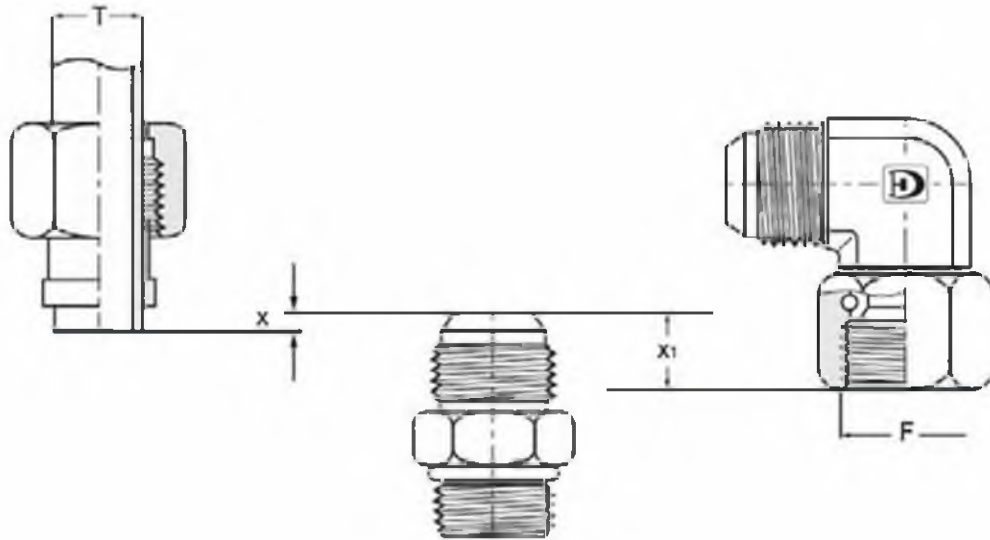

Technical Data

T Tube O.D		F Thread	X	X1	Assembly Torque	Standard Working Pressures				Working Pressures	
mm	in.	JIC	mm	mm		SAE J 514		ISO 8434-2		SAE J 514 with a-ling	
					Nm	psi	bar	Mpa	bar	Mpa	bar
8	1/4	7/16-20	2.0	10.0	13-15	5,000	350	31.5	315	80.0	800
8	5/16	1/2-20	2.0	11.0	16-25	5,000	350	31.5	315	80.0	800
10	3/8	9/16-18	2.0	11.5	24-31	5,000	350	25.0	250	60.0	600
12	1/2	3/4-16	3.0	13.0	45-62	4,500	315	25.0	250	50.0	500
14	-	7/8-14	3.5	15.5	65-72	3,500	240	20.0	200	50.0	500
15	-										
16	5/8										
18	3/4	1*1/16-12	3.5	17.5	92-100	3,000	240	20.0	200	50.0	500
20	-										
22	7/8	1*3/16-12	3.5	18.0	118-130	3,000	210	18.0	180	50.0	500
26	1"	1*5/16-12	3.5	18.5	127-145	3,000	210	16.0	160	42.0	420
30	-	1*5/8-12	5.0	20.5	175-190	2,500	170	12.5	125	42.0	420
32	1*1/4										
38	1*1/2	1*7/8-12	5.0	23.0	215-240	2,000	140	10.0	100	42.0	420

Note :

1. Material : AISI 316 and Carbon steel
2. 1 bar = 0.1 Mpa = 14.5 psi

37° Flared Tube Fitting

SAE J514

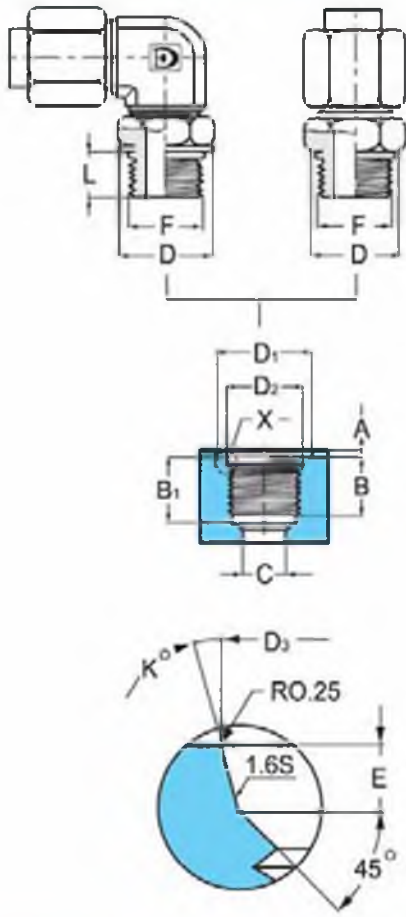

SAE J475 STRAIGHT THREAD PORTS

O-Ring sealing.

D₃ diameter must be concentric to thread.
Max. allowed error 0.13 mm.

Spot-faced surface must be square to thread in port.

Machining operations such as A and D₁ not required
when port surface complies with requirements.

Detail X

Table of Dimensions

F (Thread)	7/16-20	1/2-20	9/16-18	3/4-16	7/8-14	1"1/16-20	1"3/16-12	1"5/16-12	1"5/8-12	1"7/8-12
Division										
OD Nom.	11.11	12.70	14.29	19.05	22.23	26.99	30.16	33.34	41.27	47.62
ID Min.	9.85	11.50	12.95	17.50	20.45	24.85	27.90	31.30	39.10	45.50
A Max.	1.50	1.50	1.50	2.50	25.00	2.50	2.50	3.00	3.00	3.00
B Min.	12.00	12.00	13.00	15.00	17.00	20.00	20.00	20.00	20.00	20.00
B₁ Min.	14.00	14.00	16.00	18.00	20.00	24.00	24.00	24.00	24.00	24.00
C Min.	4.40	6.00	8.00	10.00	13.00	16.00	19.00	22.00	28.00	34.00
D	16.50	18.50	20.50	26.00	29.50	36.50	40.50	44.50	55.00	62.00
D₁ Min.	21.00	23.00	25.00	30.00	34.00	41.00	45.00	49.00	58.00	65.00
D₂ Min.	15.00	16.00	18.00	22.00	26.00	32.00	35.00	38.00	48.00	54.00
D₃ <small>+0.1 0</small>	12.40	14.00	15.60	20.60	23.90	29.20	32.30	35.50	43.50	49.80
E <small>+0.4 0</small>	2.40	2.40	2.50	2.50	2.50	3.30	3.30	3.30	3.30	3.30
K ± 1°	12°	12°	12°	15°	15°	15°	15°	15°	15°	15°
L	9.50	9.50	10.50	12.00	13.50	15.50	15.50	15.50	15.50	15.50
O-Ring	OR3-904	OR3-905	OR3-906	OR3-908	OR3-910	OR3-912	OR3-914	OR3-916	OR3-920	OR3-924
Assembly torque (Nm)	21	27	40	78	110	180	230	285	320	400

Standard O-Rings : NBR SHORE-A 85 (Max. temp. rang. -30 °C +120 °C). Additional compounds available on request.
For special applications, please contact our technical department.

37° Flared Tube Fitting

SAE J514

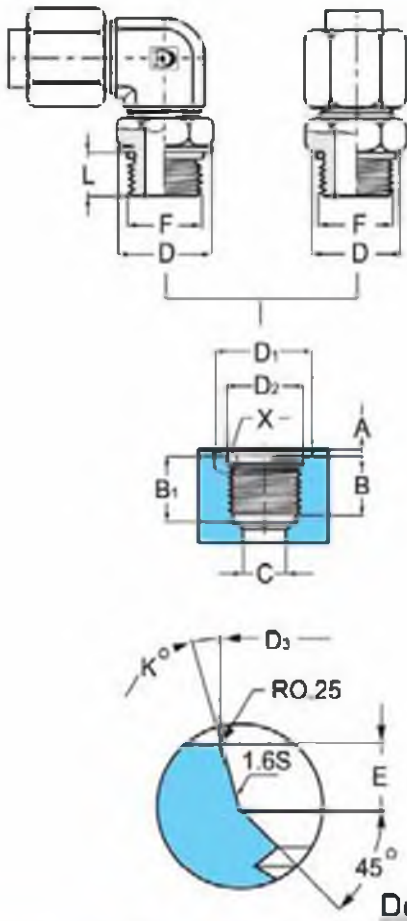

METRIC PARALLEL THREAD PORTS (ISO 6149)

O-Ring sealing.

D₃ diameter must be concentric to thread.
Max. allowed error 0.13 mm.

Spot-faced surface must be square to thread in port.

Machining operations such as A and D₁ not required
when port surface complies with requirements.

Table of Dimensions

F (Thread)	Division										
	M10 × 1.5	M12 × 1.5	M14 × 1.5	M16 × 1.5	M18 × 1.5	M20 × 1.5	M22 × 1.5	M27 × 2.0	M33 × 2.0	M42 × 2.0	M48 × 2.0
OD Nom.	10.00	12.00	14.00	16.00	18.00	20.00	22.00	27.00	33.00	42.00	48.00
ID Min.	8.90	10.30	12.30	14.30	16.30	18.30	20.30	24.80	30.80	39.80	45.80
A Max.	1.00	1.50	1.50	1.50	2.00	2.00	2.00	2.00	12.50	2.50	2.50
B Min.	10.00	11.50	11.50	13.00	14.50	14.50	15.50	19.00	19.00	19.50	22.00
B ₁ Min.	11.50	14.00	14.00	15.50	16.50	16.50	18.00	22.00	22.00	22.50	25.00
C Min.	4.00	6.00	7.00	9.00	11.00	12.00	14.00	16.00	22.00	30.00	36.00
D	14.50	17.50	19.50	22.50	24.50	27.50	27.50	32.50	41.50	50.50	55.50
D ₁ Min.	20.00	22.00	25.00	28.00	29.00	32.00	34.00	40.00	49.00	60.00	68.00
D ₂ Min.	14.50	17.50	19.50	22.50	24.50	25.50	27.50	32.50	41.50	50.50	55.50
D ₃ ^{+0.1} ₀	11.10	13.80	15.80	17.80	19.80	21.80	23.80	29.40	35.40	44.40	50.40
E ^{+0.4} ₀	1.60	2.40	2.40	2.40	2.40	2.40	2.40	3.10	3.10	3.10	3.10
K ± 1°	12°	15°	15°	15°	15°	15°	15°	15°	15°	15°	15°
L	9.00	9.00	10.50	12.00	13.50	13.50	14.00	17.00	17.00	17.50	20.00
O-Ring	KP-B-P9	KP-B-P10	KP-B-P12	KP-B-P14	KP-B-P16	KP-B-P18	KP-B-P20	KP-B-P24	KP-B-P30	KP-B-P39	KP-B-P45
Assembly torque (Nm)	20	35	45	55	68	80	98	180	310	330	400

Standard O-Rings : NBR SHORE-A 85 (Max. temp. rang. -30 °C +120 °C) Additional compounds available on request.
For special applications, please contact our technical department.

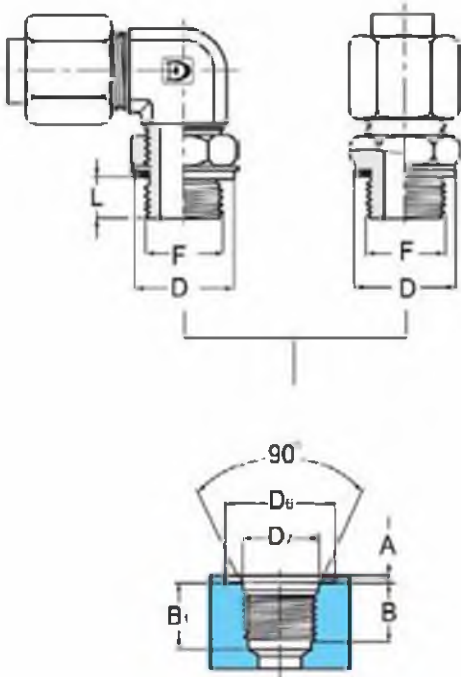

BSPP THREAD PORTS

O-Ring and retainer ring sealing.

Spot-faced surface must be square to thread in port.

Machining operations such as A and D₆ not required when port surface complies with requirements.

Table of Dimensions

F (Thread)	1/8" - 28	1/4" - 19	3/8" - 19	1/2" - 14	3/4" - 14	1" - 11	1 1/4" - 11	1 1/2" - 11
Division								
OD Nom.	9.73	13.16	16.66	20.96	26.44	33.25	41.91	47.80
ID Min.	8.60	11.45	14.95	18.65	24.12	30.30	38.95	44.85
A Max.	1.00	1.50	2.00	2.50	2.50	2.50	2.50	2.50
B Min.	8.00	12.00	12.00	14.00	16.00	18.00	20.00	22.00
B₁ Min.	13.00	18.50	18.50	22.00	24.00	27.00	29.00	31.00
D	15.50	19.50	24.00	28.50	35.00	43.00	52.50	58.50
D₆ Min.	16.50	21.50	25.50	30.00	36.50	45.00	55.00	61.00
D₇	9.70	13.20	16.80	21.00	26.40	33.30	41.90	47.80
L	6.50	9.00	9.50	11.50	13.50	15.00	16.00	16.00
O-Ring	KP-B-P8	KP-B-P11	KP-B-P14	KP-B-P18	KP-B-P24	KP-B-P29	KP-B-P38	KP-B-P44
Assembly torque (Nm)	20	35	70	100	190	300	330	400

Standard O-Rings : NBR SHORE-A 85 ± (Max. temp. rang. -30 °C +120 °C). Additional compounds available on request.
For special applications, please contact our technical department.

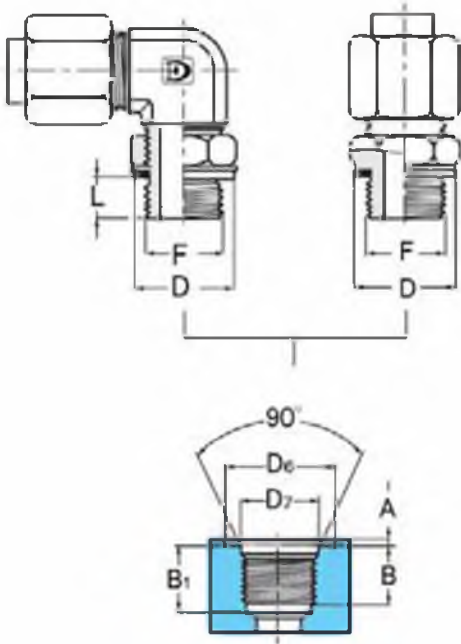

METRIC PARALLEL THREAD SEAL PORTS

O-Ring and retainer ring sealing.

Spot-faced surface must be square to thread in port.

Machining operations such as A and D₆ not required when port surface complies with requirements.

Table of Dimensions

F (Thread)	M10 × 1.0	M12 × 1.5	M14 × 1.5	M16 × 1.5	M18 × 1.5	M20 × 1.5	M22 × 1.5	M26 × 1.5	M27 × 2.0	M33 × 2.0	M42 × 2.0	M48 × 2.0
Division												
OD Nom.	10.00	12.00	14.00	16.00	18.00	20.00	22.00	28.00	27.00	33.00	42.00	48.00
ID Min.	8.90	10.30	12.30	14.30	16.30	18.30	20.30	24.30	24.80	30.80	39.80	45.80
A Max.	1.00	1.50	1.50	1.50	2.00	2.00	2.50	2.50	2.50	2.50	2.50	2.50
B Min.	8.00	12.00	12.00	12.00	14.00	14.00	14.00	16.00	16.00	18.00	20.00	22.00
B₁ Min.	13.50	18.50	18.50	18.50	20.50	20.50	20.50	22.50	22.50	28.00	28.00	30.00
D	15.50	18.50	19.50	23.00	28.00	28.00	29.00	35.00	35.00	43.00	53.00	59.00
D₆ Min.	16.50	20.00	21.50	24.50	30.00	30.00	31.50	38.50	38.50	45.00	55.00	62.50
D₇	10.00	12.00	14.00	16.00	20.00	20.00	22.00	26.00	26.00	33.00	42.00	48.00
L	8.00	9.00	9.00	10.50	12.00	12.00	12.50	13.50	14.50	14.50	15.00	17.60
O-Ring	KP-B-P9	KP-B-P10	KP-B-P12	KP-B-P14	KP-B-P16	KP-B-P18	KP-B-P20	KP-B-P24	KP-B-P24	KP-B-P30	KP-B-P39	KP-B-P45
Assembly torque (Nm)	20	20	20	20	20	20	20	20	20	20	20	20

Standard O-Rings : NBR SHORE-A 85 (Max. temp. rang. -30 °C +120 °C). Additional compounds available on request.
For special applications, please contact our technical department.

NPTF THREAD SEAL

The sealing action being achieved by the male and female tapered threads is therefore suitable to withstand high pressures. If required, the sealing action can be enhanced with auxiliary compounds or tapes.

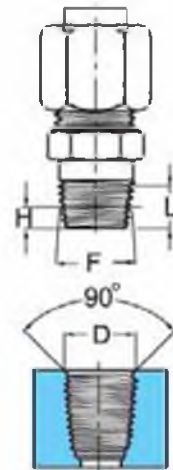

F (Thread)	1/8"-27	1/4"-18	3/8"-18	1/2"-14	3/4"-14	1"-11 1/2	1 1/4"-11 1/2	1 1/2"-11 1/2
Division								
D	10.24	13.61	17.05	21.22	26.58	33.22	41.98	48.05
H	4.10	5.80	6.10	8.10	8.60	10.20	10.70	10.70
L working thread	6.70	10.00	10.50	13.50	14.00	17.00	18.00	18.50

BSPT THREAD SEALS

The sealing is achieved by matching a male tapered and female parallel threads. This type of seal is not recommended under high pressures.

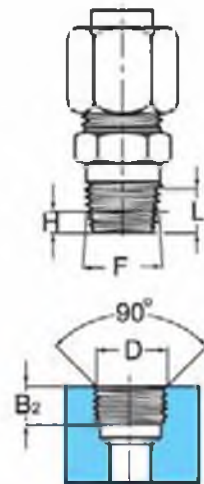

F (Thread)	1/8"-28	1/4"-19	3/8"-19	1/2"-14	3/4"-14	1"-14	1 1/4"-11	1 1/2"-11
Division								
B Min.	5.50	8.50	8.50	10.50	13.00	14.50	17.00	17.00
D	9.72	13.15	16.66	20.95	26.44	33.24	41.91	47.80
H	4.00	6.00	6.40	8.20	9.50	10.40	12.70	12.70
L working thread	6.50	9.70	10.10	13.20	14.50	14.50	19.10	19.10

ASSEMBLY PROCEDURE FOR RADIALLY ADJUSTABLE FITTINGS.

ON SAE, METRIC ISO 6149

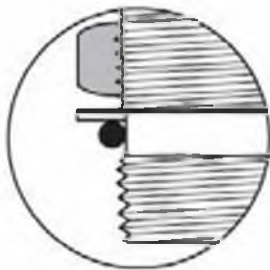
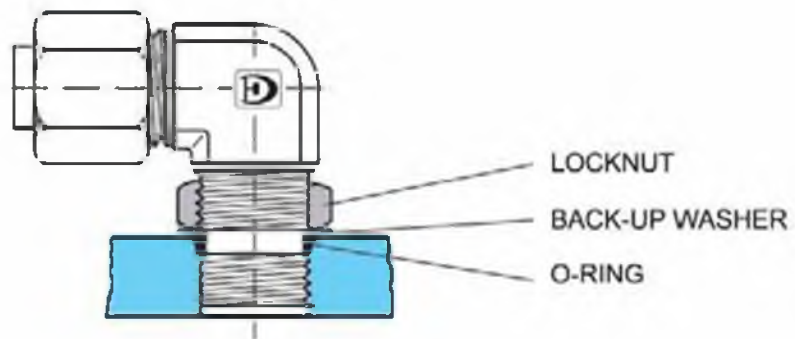

For adjustable positioning, O-Ring and back-up washer should be in proper position on non-threaded section nearest to locknut. Lubrication of O-Ring is recommended.

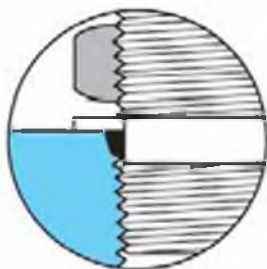

Screw fitting by hand into straight thread port until back-up washer contacts face of port.

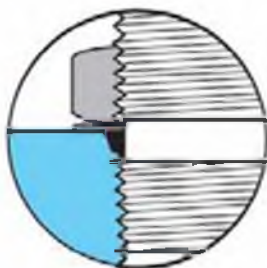

To position fitting, unscrew up to one full turn then hold fitting in desired position and tighten locknut until back-up washer contacts face of port and force O-Ring within port cavity.

ASSEMBLY PROCEDURE FOR RADIALLY ADJUSTABLE FITTINGS.

ON SAE, METRIC ISO 6149

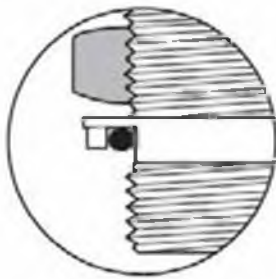
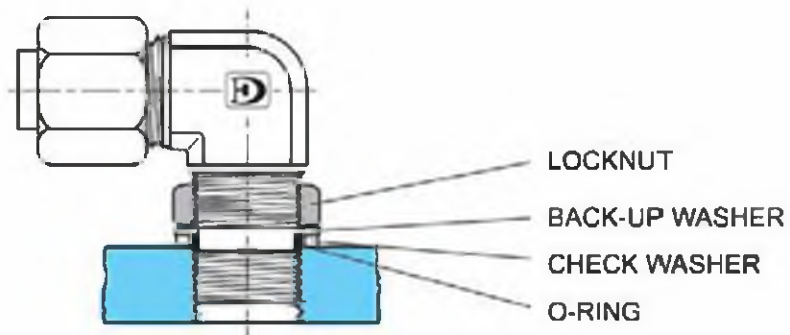

For adjustable positioning, O-Ring and back-up washer should be in proper position on non-threaded section nearest to locknut. Lubrication of O-Ring is recommended.

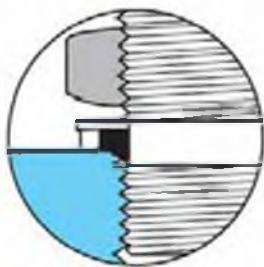

Screw fitting by hand into straight thread port until check washer contacts face of port.



To position fitting, unscrew up to one full turn then hold fitting in desired position and tighten locknut until check washer is in contact with face of port.

SPECIAL FITTINGS.

CODING PROCEDURE

Fittings having thread combinations other than those listed in our catalogue can be ordered provided the following conditions are met :

- The geometric shape of any new fitting meets with those in the table below.
- The nominal dimension of the new fitting's ends are shown in our catalogue.
- The new fitting envelope dimensions will be those originated by the biggest thread.

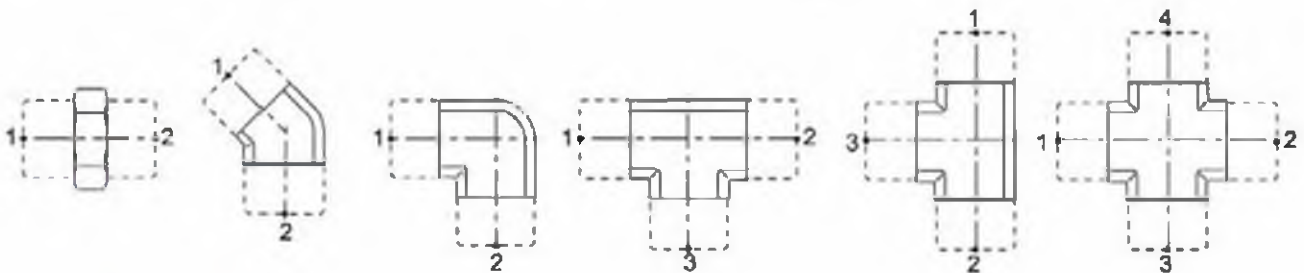

EXAMPLES :

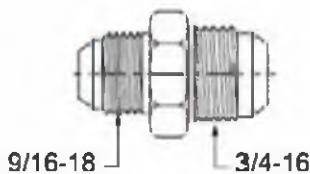

Should you wish a fitting in page 16 with following threads:
FUR (9/16-18) (3/4-16) this will be by for encoded as : FUR 6T - 8T.

Example 1. Tube to Tube Connection	Option (O-Ring Seal)
<u>FUR</u> <u>6T</u> - <u>8T</u> - <u>S316</u>	<u>FOUR</u> <u>6T</u> - <u>8T</u> - <u>S316</u>
1 2 5	1 2 5

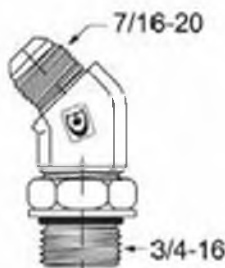

From page 37 you may order :
FOLMB (7/16-20) (3/4-16) by for encoded as FOLMB 4T - 08U.

Example 2. Tube to Tube Connection	Option (O-Ring Seal)
<u>FOLMB</u> <u>4T</u> - <u>08U</u> - <u>S316</u>	<u>FOOLMB</u> <u>4T</u> - <u>08U</u> - <u>S316</u>
1 2 3 5	1 2 3 5

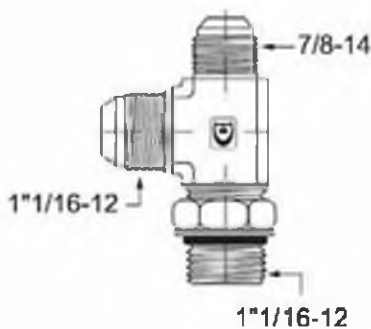

From page 39 you may order :
FORTM - (7/8-14) (1 1/16-12) (1 1/16-12) by for encoded as FORTM 10T 12T - 12U.

Example 3. Tube to Tube Connection	Option (O-Ring Seal)
<u>FORTM</u> <u>10T12T</u> - <u>12U</u> - <u>S316</u>	<u>FOORTM</u> <u>10T12T</u> - <u>12U</u> - <u>S316</u>
1 2 3 5	1 2 3 5

- | | |
|----------------------|---------------------------------------|
| 1. Name of Fittings | : "Refer to Index" (Complete fitting) |
| 2. Tube O.D | : See Tubing Designator |
| 3. Thread Connection | : See Thread Designator |
| 4. Elastomer Seal | : O-Ring |
| 5. Material | : See Material Designator |

Tube Designator

Inch Tube

Tube O.D	1/8"	3/8"	1/2"	1-1/2"	2"
Identifier	4T	6T	8T	24T	32T

Metric Tube

Tube O.D	4mm	6mm	8mm	38mm	42mm
Identifier	4M	6M	8M	38M	42M

Thread Designator

Pipe Thread

Nominal Size	1/8"	1/4"	3/8"	1/2"	3/4"	1"	1-1/4"	1-1/2"
Identifier	01	02	03	04	06	08	10	12

Unified Thread

Size	7/16	9/16	3/4	7/8	1-5/16	1-5/8	1-5/8
Identifier	04	06	08	10	12	16	20

Thread Symbol

Size	Symbol	Specification
Taper Thread	R	BS 21 (BSPT), ISO 7/1
	N	ASME / ANSI B1. 20. 1 (NPT)
Parallel Thread	G	BS 2779 (BSPP), ISO 228/1
	U	ASME B1.1 (Unified)

Material designator

Material	Stainless Steel	Carbon Steel	Brass
Identifier	S316 / S316L	Stel	Bras

EZY MAT - II Portable flaring machine



Overall dimensions : 400 x 400 x 230. Weight : 50 Kg.



Flaring device



Pressure switch



Clamping grip

Benefit :

- Very easy operating.
- Ensure Constant quality.
- Quick flaring time.

Caution!

Do not actuate the flaring cone without first inserting the tube.

Clamping grips for EZY MAT - II

Tube O.D (mm.)	Part No.	Tube O.D (in.)	Part No.
6	M-FG06	1/4	M-FG04T
8	M-FG08	5/16	M-FG05T
10	M-FG10	3/8	M-FG06T
12	M-FG12	1/2	M-FG08T
14	M-FG14		
15	M-FG15		
16	M-FG16	5/8	M-FG10T
18	M-FG18		
20	M-FG20	3/4	M-FG12T
22	M-FG22	7/8	M-FG14T
25	M-FG25	1	M-FG16T
28	M-FG28		
30	M-FG30		
32	M-FG32	1-1/4	M-FG20T
35	M-FG35		
38	M-FG38	1-1/2	M-FG24T
42	M-FG42		

Union

FU

SAE J514(070101)

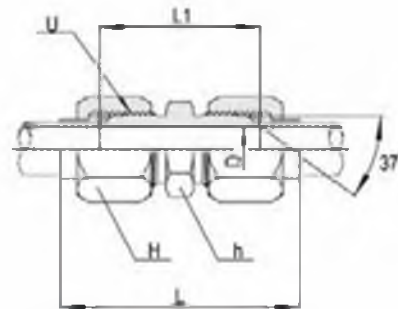

Part No.	Tube O.D.		U (UNF)	h (HEX)	H (HEX)	D	L	L1
	Inch	Metnc						
FU-2T	1/8"	3	5/16"-24	11.0	9.5	1.6	45.3	29.7
FU-3T	3/16"	4	3/8"-24	11.0	11.0	3.2	50.0	31.2
FU-4T	1/4"	6	7/16"-20	12.0	14.2	4.4	53.0	34.8
FU-5T	5/16"	8	1/2"-20	14.2	15.8	6.0	55.6	34.8
FU-6T	3/8"	10	9/16"-18	16.0	17.4	7.5	59.6	35.8
FU-8T	1/2"	12	3/4"-16	21.0	22.2	9.9	66.5	41.1
FU-10T	5/8"	16	7/8"-14	23.8	25.4	12.3	81.0	47.8
FU-12T	3/4"	18.20	1 1/16"-12	29.0	31.7	15.5	85.9	54.9
FU-14T	7/8"	22	1 3/16"-12	32.0	34.9	18.0	91.3	58.1
FU-16T	1"	25	1 5/16"-12	38.0	38.1	21.5	95.2	57.2
FU-20T	1-1/4"	32	1 5/8"-12	46.0	50.8	27.5	98.7	61.7
FU-24T	1-1/2"	38	1 7/8"-12	50.0	57.1	33.0	123.2	69.8
FU-32T	2"	50	2 1/2"-12	66.7	73.0	45.0	141.4	86.4

All dimensions are in millimeters unless otherwise specified. Dimensions are for reference only, subject to change.

Union Elbow

FL

SAE J514(070201)

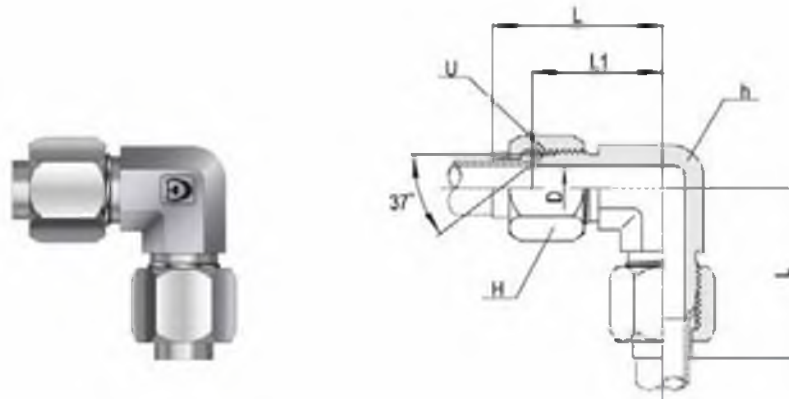

Part No.	Tube O.D.		U (UNF)	D	h (HEX)	H (HEX)	L	L1
	Inch	Metric						
FL-2T	1/8"	3	5/16"-24	1.6	11.1	9.5	27.4	19.6
FL-3T	3/16"	4	3/8"-24	3.2	11.1	11.0	30.5	21.1
FL-4T	1/4"	6	7/16"-20	4.4	11.1	14.2	31.7	22.6
FL-5T	5/16"	8	1/2"-20	6.0	14.2	15.8	34.5	24.1
FL-6T	3/8"	10	9/16"-18	7.5	14.2	17.4	38.8	26.9
FL-8T	1/2"	12	3/4"-16	9.9	18.0	22.2	44.5	31.8
FL-10T	5/8"	16	7/8"-14	12.3	22.2	25.4	53.4	38.8
FL-12T	3/4"	18.20	1 1/16"-12	15.5	27.0	31.7	57.7	42.2
FL-14T	7/8"	22	1 3/16"-12	18.0	33.3	34.9	63.3	45.7
FL-16T	1"	25	1 5/16"-12	21.5	33.3	38.1	65.0	46.0
FL-20T	1-1/4"	32	1 5/8"-12	37.5	41.3	50.8	70.8	52.3
FL-24T	1-1/2"	38	1 7/8"-12	33.0	47.6	57.1	85.8	59.2
FL-32T	2"	50	2 1/2"-12	45.0	63.5	73.0	105.2	77.7

All dimensions are in millimeters unless otherwise specified. Dimensions are for reference only, subject to change.

Union Tee

FT

SAE J514(070401)

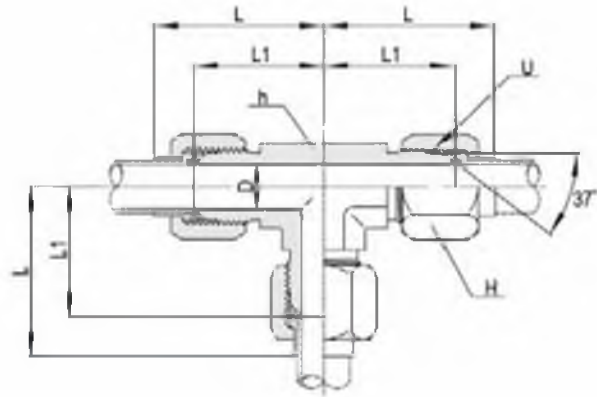

Part No.	Tube O.D.		U (UNF)	D	h (HEX)	H (HEX)	L	L1
	Inch	Metric						
FT-2T	1/8"	3	5/16"-24	1.6	11.1	9.5	27.4	19.8
FT-3T	3/16"	4	3/8"-24	3.2	11.1	11.0	30.5	21.1
FT-4T	1/4"	6	7/16"-20	4.4	11.1	14.2	31.7	22.6
FT-5T	5/16"	8	1/2"-20	6.0	14.2	15.8	34.5	24.1
FT-6T	3/8"	10	9/16"-18	7.5	14.2	17.4	38.8	26.9
FT-8T	1/2"	12	3/4"-16	9.9	19.0	22.2	44.5	31.8
FT-10T	5/8"	16	7/8"-14	12.3	22.2	25.4	53.4	36.8
FT-12T	3/4"	18,20	1 1/16"-12	15.5	27.0	31.7	57.7	42.2
FT-14T	7/8"	22	1 3/16"-12	18.0	33.3	34.9	63.3	45.7
FT-16T	1"	25	1 5/16"-12	21.5	34.9	38.1	65.0	46.0
FT-20T	1-1/4"	32	1 5/8"-12	37.5	41.3	50.8	70.8	52.3
FT-24T	1-1/2"	38	1 7/8"-12	33.0	47.6	57.1	85.9	59.2
FT-32T	2"	50	2 1/2"-12	45.0	63.5	73.0	105.2	77.7

All dimensions are in millimeters unless otherwise specified. Dimensions are for reference only, subject to change.

Union Cross

FC

SAE J514(070501)

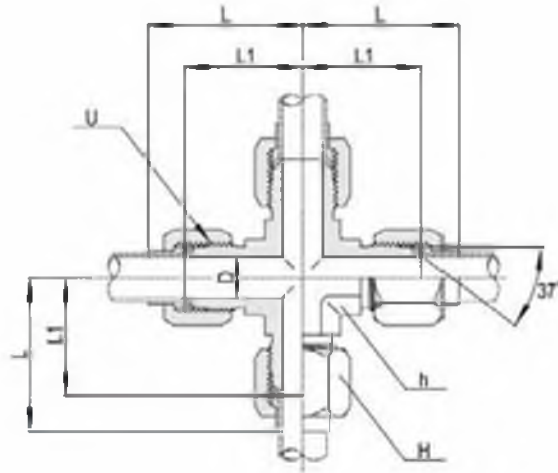

Part No.	Tube O.D.		U (UNF)	D	h (HEX)	H (HEX)	L	L1
	Inch	Metric						
FC-2T	1/8"	3	5/16"-24	1.6	11.1	9.5	27.4	19.8
FC-3T	3/16"	4	3/8"-24	3.2	11.1	11.0	30.5	21.1
FC-4T	1/4"	6	7/16"-20	4.4	11.1	14.2	31.7	22.8
FC-5T	5/16"	8	1/2"-20	6.0	14.2	15.8	34.5	24.1
FC-6T	3/8"	10	9/16"-18	7.5	14.2	17.4	38.8	26.9
FC-8T	1/2"	12	3/4"-16	8.9	19.0	22.2	44.5	31.8
FC-10T	5/8"	16	7/8"-14	12.3	22.2	25.4	53.4	36.8
FC-12T	3/4"	18.20	1 1/16"-12	15.5	27.0	31.7	57.7	42.2
FC-14T	7/8"	22	1 3/16"-12	18.0	33.3	34.9	63.3	45.7
FC-18T	1"	25	1 5/16"-12	21.5	34.9	38.1	65.0	46.0
FC-20T	1-1/4"	32	1 5/8"-12	37.5	41.3	50.8	70.8	52.3
FC-24T	1-1/2"	38	1 7/8"-12	33.0	47.6	57.1	85.9	59.2
FC-32T	2"	50	2 1/2"-12	45.0	63.5	73.0	105.2	77.7

All dimensions are in millimeters unless otherwise specified. Dimensions are for reference only, subject to change.

Bulkhead Union

FBU

SAE J514(070601)

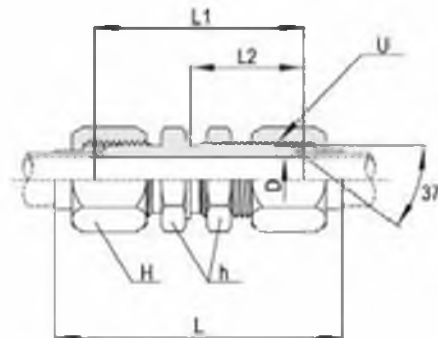

Part No.	Tube O.D.		U (UNF)	D	h (HEX)	H (HEX)	L	L1	L2
	Inch	Metric							
FBU-2T	1/8"	3	5/16"-24	1.6	14.2	9.5	63.1	47.5	28.2
FBU-3T	3/16"	4	3/8"-24	3.2	15.8	11.0	67.1	48.3	28.2
FBU-4T	1/4"	6	7/16"-20	4.4	17.4	14.2	70.8	52.6	30.5
FBU-5T	5/16"	8	1/2"-20	6.0	19.0	15.8	73.4	52.6	30.5
FBU-6T	3/8"	10	9/16"-18	7.5	20.6	17.4	79.2	55.4	32.5
FBU-8T	1/2"	12	3/4"-16	9.9	25.4	22.2	87.4	62.0	36.6
FBU-10T	5/8"	16	7/8"-14	12.3	28.5	25.4	102.8	69.6	40.1
FBU-12T	3/4"	18,20	1 1/16"-12	15.5	34.9	31.7	109.5	78.5	44.4
FBU-14T	7/8"	22	1 3/16"-12	18.0	38.1	34.9	114.4	79.2	44.4
FBU-16T	1"	25	1 5/16"-12	21.5	41.2	38.1	117.8	79.8	44.4
FBU-20T	1-1/4"	32	1 5/8"-12	37.5	47.6	50.8	121.1	84.1	45.7
FBU-24T	1-1/2"	38	1 7/8"-12	33.0	53.9	57.1	142.8	89.4	46.0
FBU-32T	2"	50	2 1/2"-12	45.0	69.8	73.0	161.7	108.7	53.1

All dimensions are in millimeters unless otherwise specified. Dimensions are for reference only, subject to change.

Weld Bulkhead Union

FBUW

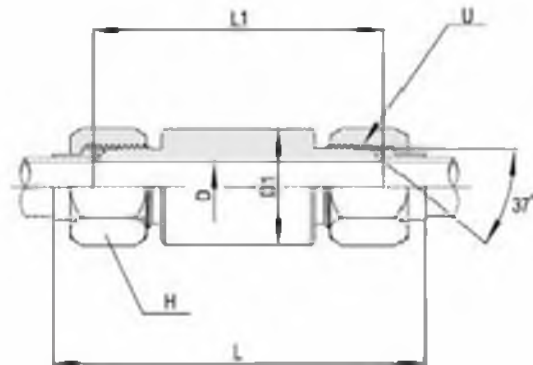

Part No.	Tube O.D.		U (UNF)	D	D1	H (HEX)	L	L1
	Inch	Metric						
FBUW-2T	1/8"	3	5/16"-24	1.8	11.0	9.5	85.6	70.0
FBUW-3T	3/16"	4	3/8"-24	3.2	11.0	11.0	88.8	70.0
FBUW-4T	1/4"	6	7/16"-20	4.4	14.0	14.2	98.2	80.0
FBUW-5T	5/16"	8	1/2"-20	8.0	16.0	15.8	120.8	100.0
FBUW-8T	3/8"	10	9/16"-18	7.5	17.0	17.4	123.8	100.0
FBUW-8T	1/2"	12	3/4"-16	9.9	22.0	22.2	125.4	100.0
FBUW-10T	5/8"	18	7/8"-14	12.3	25.0	25.4	143.2	110.0
FBUW-12T	3/4"	18.20	1 1/16"-12	15.5	30.0	31.7	151.0	120.0
FBUW-14T	7/8"	22	1 3/16"-12	18.0	32.0	34.9	165.2	130.0
FBUW-16T	1"	25	1 5/16"-12	21.5	40.0	38.1	168.0	130.0
FBUW-20T	1-1/4"	32	1 5/8"-12	27.5	46.0	50.8	177.0	140.0
FBUW-24T	1-1/2"	38	1 7/8"-12	33.0	50.0	57.1	193.4	140.0
FBUW-32T	2"	50	2 1/2"-12	45.0	70.0	73.0	205.0	150.0

All dimensions are in millimeters unless otherwise specified. Dimensions are for reference only, subject to change.

Female Bulkhead Union

FBFC

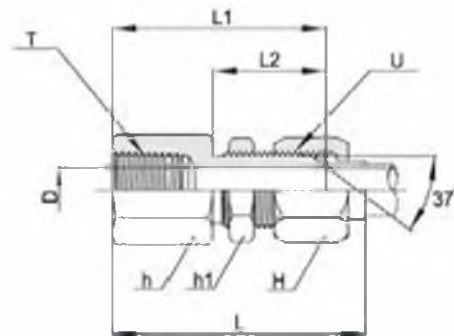

Part No.	Tube O.D.		U (UNF)	T (NPT)	D	h [HEX]	h1 [HEX]	H [HEX]	L	L1	L2
	Inch	Metric									
FBFC2T-01N	1/8"	3	5/16"-24	1/8"	1.6	14.2	14.2	9.5	49.0	41.2	28.2
FBFC3T-01N	3/16"	4	3/8"-24	1/8"	3.2	14.2	15.8	11.0	50.6	41.2	28.2
FBFC4T-01N	1/4"	6	7/16"-20	1/8"	4.4	14.2	17.4	14.2	52.6	43.5	30.5
FBFC5T-01N	5/16"	8	1/2"-20	1/8"	6.0	14.2	19.0	15.8	53.9	43.5	30.5
FBFC8T-02N	5/8"	10	9/16"-18	1/4"	7.5	19.0	20.8	17.4	62.5	50.5	32.5
FBFC8T-03N	1/2"	12	3/4"-16	3/8"	9.9	22.2	25.4	22.2	69.3	56.6	36.6
FBFC10T-04N	5/8"	18	7/8"-14	1/2"	12.3	29.0	28.5	25.4	82.7	66.1	40.1
FBFC12T-06N	3/4"	18,20	1 1/16"-12	3/4"	15.5	34.9	34.9	31.7	88.0	71.4	44.4
FBFC14T-06N	7/8"	22	1 3/16"-12	3/4"	18.0	34.9	38.1	34.9	89.0	71.4	44.4
FBFC16T-08N	1"	25	1 5/16"-12	1"	21.5	41.2	41.2	38.1	94.4	75.4	44.4
FBFC20T-10N	1-1/4"	32	1 5/8"-12	1-1/4"	27.5	50.8	47.6	50.8	99.2	80.7	45.7
FBFC24T-12N	1-1/2"	38	1 7/8"-12	1-1/2"	33.0	60.0	53.9	57.1	107.7	81.0	46.0
FBFC32T-16N	2"	50	2 1/2"-12	2"	45.0	73.0	69.8	73.0	120.8	93.1	53.1

• Pipe Thread NPT(N) or PT(R).

All dimensions are in millimeters unless otherwise specified. Dimensions are for reference only, subject to change.

Bulkhead Union Elbow

FBL

SAE J514(070701)

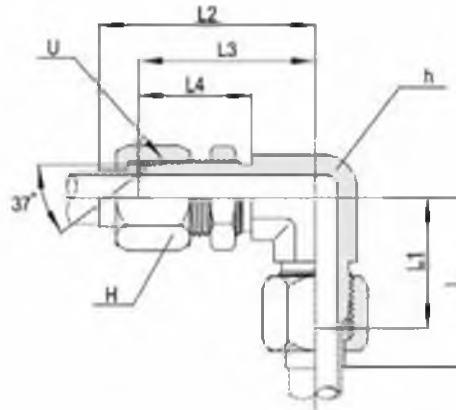

Part No.	Tube O.D.		U (UNF)	h [HEX]	H [HEX]	L	L1	L2	L3	L4
	Inch	Millia								
FBL-2T	1/8"	3	5/16"-24	11.1	9.5	30.2	22.4	45.9	38.1	23.4
FBL-3T	3/16"	4	3/8"-24	11.1	11.0	33.3	23.9	47.5	38.1	23.4
FBL-4T	1/4"	6	7/16"-20	11.1	14.2	33.7	24.6	49.5	40.4	25.9
FBL-5T	5/16"	8	1/2"-20	14.3	15.8	37.3	26.9	54.1	43.7	25.9
FBL-6T	3/8"	10	9/16"-18	14.3	17.4	39.8	27.7	57.9	46.0	27.7
FBL-8T	1/2"	12	3/4"-16	19.0	22.2	47.2	34.5	66.3	53.6	31.8
FBL-10T	5/8"	18	7/8"-14	22.2	25.4	58.2	39.6	77.3	60.7	35.8
FBL-12T	3/4"	18,20	1 1/16"-12	27.0	31.7	60.7	45.2	83.1	67.8	39.6
FBL-14T	7/8"	22	1 3/16"-12	33.3	34.9	66.4	48.8	88.7	71.1	39.6
FBL-16T	1"	25	1 5/16"-12	33.3	38.1	68.3	49.3	90.1	71.1	39.6
FBL-20T	1-1/4"	32	1 5/8"-12	41.3	50.8	73.6	55.1	97.7	79.2	40.9
FBL-24T	1-1/2"	38	1 7/8"-12	47.6	57.1	86.1	59.4	113.6	86.9	41.1
FBL-32T	2"	50	2 1/2"-12	83.5	73.0	100.9	73.4	131.9	104.4	48.5

All dimensions are in millimeters unless otherwise specified. Dimensions are for reference only, subject to change.

Female Bulkhead Union

FBFC

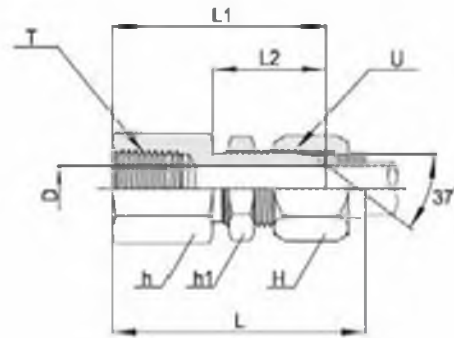

Part No.	Tube O.D.		U (UNF)	T (NPT)	D	h (HEX)	h1 (HEX)	H (HEX)	L	L1	L2
	Inch	Metric									
FBFC2T-01N	1/8"	3	5/16"-24	1/8"	1.6	14.2	14.2	9.5	49.0	41.2	28.2
FBFC3T-01N	3/16"	4	3/8"-24	1/8"	3.2	14.2	15.8	11.0	50.6	41.2	28.2
FBFC4T-01N	1/4"	6	7/16"-20	1/8"	4.4	14.2	17.4	14.2	52.6	43.5	30.5
FBFC5T-01N	5/16"	8	1/2"-20	1/8"	6.0	14.2	19.0	15.8	53.9	43.5	30.5
FBFC8T-02N	3/8"	10	9/16"-18	1/4"	7.5	19.0	20.8	17.4	62.5	50.5	32.5
FBFC8T-03N	1/2"	12	3/4"-16	3/8"	9.9	22.2	25.4	22.2	69.3	56.6	36.6
FBFC10T-04N	5/8"	18	7/8"-14	1/2"	12.3	29.0	28.5	25.4	82.7	66.1	40.1
FBFC12T-06N	3/4"	18,20	1 1/16"-12	3/4"	15.5	34.9	34.9	31.7	86.0	71.4	44.4
FBFC14T-06N	7/8"	22	1 3/16"-12	3/4"	18.0	34.9	38.1	34.9	89.0	71.4	44.4
FBFC16T-08N	1"	25	1 5/16"-12	1"	21.5	41.2	41.2	38.1	94.4	75.4	44.4
FBFC20T-10N	1-1/4"	32	1 5/8"-12	1-1/4"	27.5	50.8	47.6	50.8	99.2	80.7	45.7
FBFC24T-12N	1-1/2"	38	1 7/8"-12	1-1/2"	33.0	60.0	53.9	57.1	107.7	81.0	46.0
FBFC32T-18N	2"	50	2 1/2"-12	2"	45.0	73.0	69.8	73.0	120.8	93.1	53.1

• Pipe Thread NPT(N) or PT(R).

All dimensions are in millimeters unless otherwise specified. Dimensions are for reference only, subject to change.

Male Connector

FMC

SAE J514(070102)

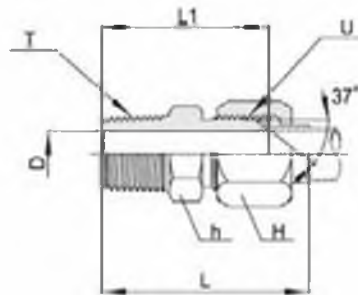

Part No.	Tube O.D.		U (UNF)	T (NPT)	D	h (HEX)	H (HEX)	L	L1
	Inch	Metnc							
FMC2T-01N	1/8"	3	5/16"-24	1/8"	1.6	11.1	9.5	36.0	28.2
FMC3T-01N	3/16"	4	3/8"-24	1/8"	3.2	11.1	11.0	38.4	29.0
FMC4T-01N	1/4"	6	7/16"-20	1/8"	4.4	12.7	14.2	40.1	31.0
FMC5T-01N	5/16"	8	1/2"-20	1/8"	8.0	14.2	15.8	41.4	31.0
FMC6T-02N	3/8"	10	9/16"-18	1/4"	7.5	15.8	17.4	48.2	36.3
FMC8T-03N	1/2"	12	3/4"-16	3/8"	9.9	20.6	22.2	51.6	38.9
FMC10T-04N	5/8"	16	7/8"-14	1/2"	12.3	20.6	25.4	64.6	48.0
FMC12T-06N	3/4"	18,20	1 1/16"-12	3/4"	15.5	28.5	31.7	67.8	52.3
FMC14T-06N	7/8"	22	1 3/16"-12	3/4"	18.0	31.7	34.9	70.7	53.1
FMC16T-08N	1"	25	1 5/16"-12	1"	21.5	34.9	38.1	77.4	58.4
FMC20T-10N	1-1/4"	32	1 5/8"-12	1-1/4"	27.5	42.8	50.8	80.7	62.2
FMC24T-12N	1-1/2"	38	1 7/8"-12	1-1/2"	33.0	50.8	57.1	94.8	68.1
FMC32T-16N	2"	50	2 1/2"-12	2"	45.0	66.6	73.0	106.5	79.0

• Pipe Thread NPT(N) or PT(R).

All dimensions are in millimeters unless otherwise specified. Dimensions are for reference only, subject to change.

Male Elbow

FLM

SAE J514(070202)

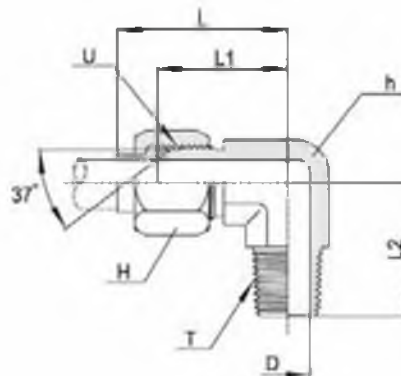

Part No.	Tube O.D.		U (UNF)	T (NPT)	D	h (HEX)	H (HEX)	L	L1	L2
	Inch	Metric								
FLM2T-01N	1/8"	3	5/16"-24	1/8"	1.8	11.1	9.5	27.4	19.6	18.3
FLM3T-01N	3/16"	4	3/8"-24	1/8"	3.2	11.1	11.0	30.5	21.1	18.3
FLM4T-01N	1/4"	6	7/16"-20	1/8"	4.4	11.1	14.2	31.7	22.6	19.8
FLM5T-01N	5/16"	8	1/2"-20	1/8"	6.0	14.3	15.8	34.5	24.1	19.8
FLM6T-02N	3/8"	10	9/16"-18	1/4"	7.5	14.3	17.4	38.8	26.9	27.7
FLM8T-03N	1/2"	12	3/4"-16	3/8"	9.9	19.0	22.2	44.5	31.8	31.0
FLM10T-04N	5/8"	16	7/8"-14	1/2"	12.3	22.2	25.4	53.4	36.8	37.3
FLM12T-06N	3/4"	18.20	1 1/16"-12	3/4"	15.5	27.0	31.7	57.7	42.2	40.4
FLM14T-06N	7/8"	22	1 3/16"-12	3/4"	18.0	33.3	34.9	63.3	45.7	42.9
FLM16T-08N	1"	25	1 5/16"-12	1"	21.5	33.3	38.1	65.0	48.0	50.0
FLM20T-10N	1-1/4"	32	1 5/8"-12	1-1/4"	27.5	41.3	50.8	70.8	52.3	60.5
FLM24T-12N	1-1/2"	38	1 7/8"-12	1-1/2"	33.0	47.6	57.1	85.9	59.2	67.1
FLM32T-16N	2"	50	2 1/2"-12	2"	45.0	63.5	73.0	105.2	77.7	76.2

* Pipe Thread NPT(N) or PT(R).

All dimensions are in millimeters unless otherwise specified. Dimensions are for reference only, subject to change.

37° Flared Tube Fitting

SAE J514

Male Run Tee

FRTM

SAE J514(070424)

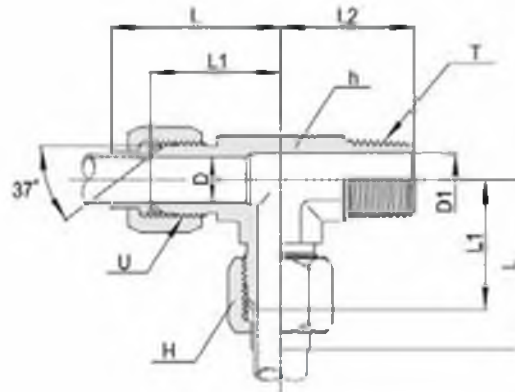

Part No	Tube O.D.		U (UNF)	T (NPT)	D	D1	h (HEX)	H (HEX)	L	L1	L2
	Inch	Metric									
FRTM2T-01N	1/8"	3	5/16"-24	1/8"	1.6	4.8	11.1	9.5	27.4	19.6	18.3
FRTM3T-01N	3/16"	4	3/8"-24	1/8"	3.2	4.8	11.1	11.0	30.5	21.1	18.3
FRTM4T-01N	1/4"	6	7/16"-20	1/8"	4.4	4.8	11.1	14.2	31.7	22.6	19.8
FRTM5T-01N	5/16"	8	1/2"-20	1/8"	6.0	4.8	14.3	15.8	34.5	24.1	19.8
FRTM6T-02N	3/8"	10	9/16"-18	1/4"	7.5	7.0	14.3	17.4	38.8	26.9	27.7
FRTM8T-03N	1/2"	12	3/4"-16	3/8"	9.9	10.3	19.0	22.2	44.5	31.8	31.0
FRTM10T-04N	5/8"	16	7/8"-14	1/2"	12.3	13.5	22.2	25.4	53.4	36.8	37.3
FRTM12T-06N	3/4"	18.20	1 1/16"-12	3/4"	15.5	18.0	27.0	31.7	57.7	42.2	40.4
FRTM14T-08N	7/8"	22	1 3/16"-12	3/4"	18.0	18.0	33.3	34.9	63.3	45.7	42.9
FRTM16T-08N	1"	25	1 5/16"-12	1"	21.5	23.8	33.3	38.1	65.0	46.0	50.0
FRTM20T-10N	1-1/4"	32	1 5/8"-12	1-1/4"	27.5	31.7	41.3	50.8	70.8	52.3	60.5
FRTM24T-12N	1-1/2"	38	1 7/8"-12	1-1/2"	33.0	38.0	47.6	57.1	85.9	59.2	67.1
FRTM32T-16N	2"	50	2 1/2"-12	2"	45.0	49.0	63.5	73.0	105.2	77.7	76.2

- Pipe Thread NPT(N) or PT(R).

All dimensions are in millimeters unless otherwise specified. Dimensions are for reference only, subject to change.

37° Flared Tube Fitting

SAE J514

Branch Tee

FBTM

SAE J514(070425)

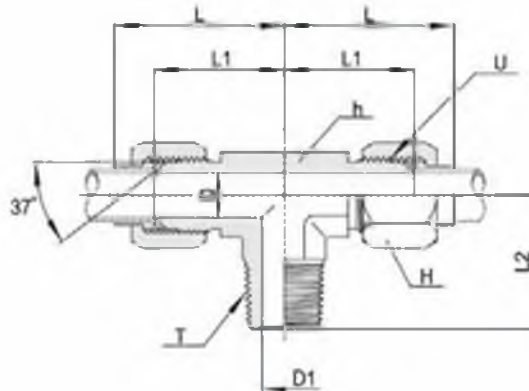

Part No.	Tube O.D.		U (UNF)	T (NPT)	D	D1	h (HEX)	H (HEX)	L	L1	L2
	Inch	Metrc									
FBTM2T-01N	1/8"	3	5/16"-24	1/8"	1.8	4.8	11.1	9.5	27.4	19.6	18.3
FBTM3T-01N	3/16"	4	3/8"-24	1/8"	3.2	4.8	11.1	11.0	30.5	21.1	18.3
FBTM4T-01N	1/4"	6	7/16"-20	1/8"	4.4	4.8	11.1	14.2	31.7	22.6	19.8
FBTM5T-01N	5/16"	8	1/2"-20	1/8"	6.0	4.8	14.3	15.8	34.5	24.1	19.8
FBTM6T-02N	3/8"	10	9/16"-18	1/4"	7.5	7.0	14.3	17.4	38.8	26.9	27.7
FBTM8T-03N	1/2"	12	3/4"-16	3/8"	9.9	10.3	19.0	22.2	44.5	31.8	31.0
FBTM10T-04N	5/8"	16	7/8"-14	1/2"	12.3	13.5	22.2	25.4	53.4	38.8	37.3
FBTM12T-06N	3/4"	18.20	1 1/16"-12	3/4"	15.5	18.0	27.0	31.7	57.7	42.2	40.4
FBTM14T-06N	7/8"	22	1 3/16"-12	3/4"	18.0	18.0	33.3	34.9	63.3	45.7	42.9
FBTM16T-08N	1"	25	1 5/16"-12	1"	21.5	23.8	35.0	38.1	65.0	48.0	50.0
FBTM20T-10N	1-1/4"	32	1 5/8"-12	1-1/4"	37.5	31.7	41.3	50.8	70.8	52.3	60.5
FBTM24T-12N	1-1/2"	38	1 7/8"-12	1-1/2"	33.0	38.0	47.6	57.1	85.9	59.2	67.1
FBTM32T-16N	2"	50	2 1/2"-12	2"	45.0	48.0	63.5	73.0	105.2	77.7	76.2

* Pipe Thread NPT(N) or PT(R)

All dimensions are in millimeters unless otherwise specified. Dimensions are for reference only, subject to change.

45° Male Elbow

FLMB

SAE J514(070302)

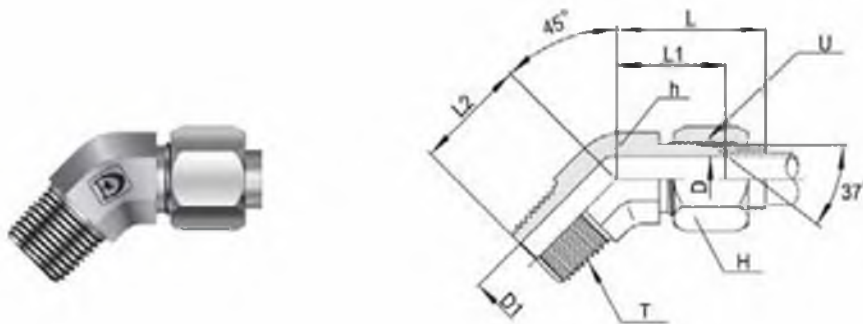

Part No.	Tube O.D.		U (UNF)	T (NPT)	D	D1	h (HEX)	H (HEX)	L	L1	L2
	Inch	Metric									
FLMB2T-01N	1/8"	3	5/16"-24	1/8"	1.6	1.8	11.1	9.5	25.3	17.5	13.2
FLMB3T-01N	3/16"	4	3/8"-24	1/8"	3.2	3.2	11.1	11.0	26.9	17.5	13.2
FLMB4T-01N	1/4"	6	7/16"-20	1/8"	4.4	4.4	11.1	14.2	27.4	18.3	16.3
FLMB5T-01N	5/16"	8	1/2"-20	1/8"	6.0	6.0	14.3	15.8	30.0	19.6	16.3
FLMB6T-02N	3/8"	10	9/16"-18	1/4"	7.5	7.5	14.3	17.4	33.0	21.1	21.8
FLMB8T-03N	1/2"	12	3/4"-16	3/8"	9.9	9.9	19.0	22.2	37.6	24.9	24.1
FLMB10T-04N	5/8"	16	7/8"-14	1/2"	12.3	12.3	22.2	25.4	44.8	28.2	29.7
FLMB12T-06N	3/4"	18,20	1 1/16"-12	3/4"	15.5	15.5	27.0	31.7	48.0	32.5	30.5
FLMB14T-08N	7/8"	22	1 3/16"-12	3/4"	18.0	18.0	33.3	34.9	54.4	36.8	33.0
FLMB16T-08N	1"	25	1 5/16"-12	1"	21.5	21.5	35.0	38.1	56.3	37.3	37.6
FLMB20T-10N	1-1/4"	32	1 5/8"-12	1-1/4"	37.6	37.6	41.3	50.8	58.9	40.4	42.4
FLMB24T-12N	1-1/2"	38	1 7/8"-12	1-1/2"	33.0	33.0	47.6	57.1	71.9	45.2	45.0
FLMB32T-16N	2"	50	2 1/2"-12	2"	45.0	45.0	63.5	73.0	83.9	56.4	53.6

* Pipe Thread NPT(N) or PT(R).

All dimensions are in millimeters unless otherwise specified. Dimensions are for reference only, subject to change.

Female Connector

FFC

SAE J514(070103)

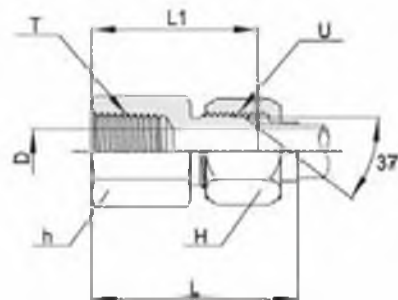

Part No.	Tube O.D.		U (UNF)	T (NPT)	D	h (HEX)	H (HEX)	L	L1
	Inch	Metric							
FFC2T-01N	1/8"	3	5/16"-24	1/8"	1.6	14.2	9.5	36.2	28.4
FFC3T-01N	3/16"	4	3/8"-24	1/8"	3.2	14.2	11.0	38.1	28.7
FFC4T-01N	1/4"	6	7/16"-20	1/8"	4.4	14.2	14.2	39.3	30.2
FFC5T-01N	5/16"	8	1/2"-20	1/8"	6.0	14.2	15.8	40.1	29.7
FFC6T-02N	3/8"	10	9/16"-18	1/4"	7.5	19.0	17.4	47.5	35.6
FFC8T-03N	1/2"	12	3/4"-16	3/8"	9.9	22.2	22.2	52.3	39.8
FFC10T-04N	5/8"	16	7/8"-14	1/2"	12.3	28.5	25.4	64.6	48.0
FFC12T-06N	3/4"	18,20	1 1/16"-12	3/4"	15.6	34.9	31.7	67.8	52.3
FFC14T-06N	7/8"	22	1 3/16"-12	3/4"	18.0	34.9	34.9	69.9	52.3
FFC18T-08N	1"	25	1 5/16"-12	1"	21.5	41.2	38.1	78.7	59.7
FFC20T-10N	1-1/4"	32	1 5/8"-12	1-1/4"	37.6	50.8	50.8	81.7	63.2
FFC24T-12N	1-1/2"	38	1 7/8"-12	1-1/2"	33.0	60.3	57.1	93.2	68.5
FFC32T-16N	2"	50	2 1/2"-12	2"	45.0	73.0	73.0	102.9	75.4

• Pipe Thread NPT(N) or PT(R).

All dimensions are in millimeters unless otherwise specified. Dimensions are for reference only, subject to change.

Female Elbow

FLF

SAE J514(070203)

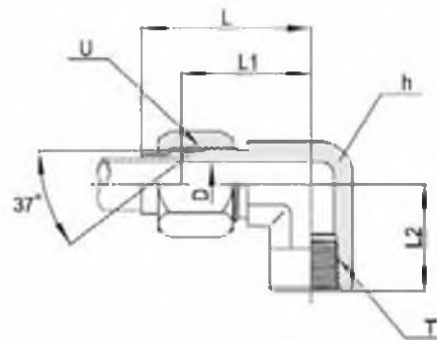

Part No.	Tube O.D.		U (UNF)	T (NPT)	D	h (HEX)	H (HEX)	L	L1	L2
	Inch	Meinc								
FLF2T-01N	1/8"	3	5/16"-24	1/8"	1.6	14.3	8.5	33.2	25.4	16.8
FLF3T-01N	3/16"	4	3/8"-24	1/8"	3.2	14.3	11.0	35.6	26.2	18.8
FLF4T-01N	1/4"	6	7/16"-20	1/8"	4.4	14.3	14.2	38.5	27.4	16.8
FLF5T-01N	5/16"	8	1/2"-20	1/8"	6.0	14.3	16.0	37.8	27.4	18.8
FLF6T-02N	3/8"	10	9/16"-18	1/4"	7.5	19.0	17.4	43.1	31.2	22.4
FLF8T-03N	1/2"	12	3/4"-16	3/8"	9.9	22.2	22.2	48.8	36.1	25.9
FLF10T-04N	5/8"	16	7/8"-14	1/2"	12.3	27.0	25.4	58.3	41.7	31.2
FLF12T-06N	3/4"	18,20	1 1/16"-12	3/4"	15.5	33.3	32.0	63.5	48.0	34.5
FLF14T-08N	7/8"	22	1 3/16"-12	3/4"	18.0	33.3	35.0	64.8	47.2	36.1
FLF16T-08N	1"	25	1 5/16"-12	1"	21.5	41.3	38.0	74.1	55.1	41.1
FLF20T-10N	1-1/4"	32	1 5/8"-12	1-1/4"	37.5	47.6	50.8	77.7	59.2	43.2
FLF24T-12N	1-1/2"	38	1 7/8"-12	1-1/2"	33.0	65.1	57.0	100.1	73.4	52.8
FLF32T-16N	2"	50	2 1/2"-12	2"	45.0	71.4	73.0	111.3	83.8	60.7

* Pipe Thread NPT(N) or PT(R).

All dimensions are in millimeters unless otherwise specified. Dimensions are for reference only, subject to change.

Female Run Tee

FRTF

SAE J514(070426)

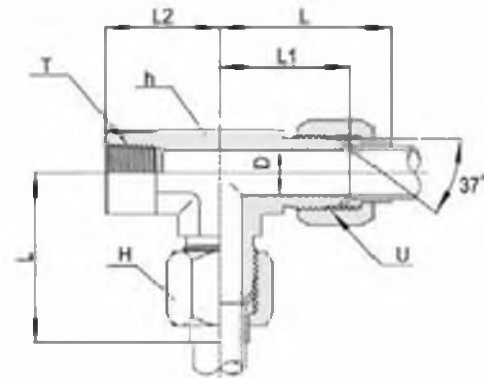

Part No.	Tube O.D.		U (UNF)	T (NPT)	D	h (HEX)	H (HEX)	L	L1	L2
	Inch	Metric								
FRTF2T-01N	1/8"	3	5/16"-24	1/8"	1.6	14.3	9.5	33.2	25.4	18.8
FRTF3T-01N	3/16"	4	3/8"-24	1/8"	3.2	14.3	11.0	35.6	26.2	18.8
FRTF4T-01N	1/4"	6	7/16"-20	1/8"	4.4	14.3	14.2	36.5	27.4	18.8
FRTF5T-01N	5/16"	8	1/2"-20	1/8"	6.0	14.3	16.0	37.8	27.4	16.8
FRTF6T-02N	5/8"	10	9/16"-18	1/4"	7.5	19.0	17.4	43.1	31.2	22.4
FRTF8T-03N	1/2"	12	3/4"-16	3/8"	9.9	22.2	22.2	48.8	36.1	25.9
FRTF10T-04N	5/8"	16	7/8"-14	1/2"	12.3	27.0	25.4	58.3	41.7	31.2
FRTF12T-06N	3/4"	18.20	1 1/16"-12	3/4"	15.5	33.3	32.0	63.5	48.0	34.5
FRTF14T-08N	7/8"	22	1 3/16"-12	3/4"	18.0	33.3	35.0	64.8	47.2	38.1
FRTF16T-08N	1"	25	1 5/16"-12	1"	21.5	41.3	38.0	74.1	55.1	41.1
FRTF20T-10N	1-1/4"	32	1 5/8"-12	1-1/4"	37.5	47.6	50.8	77.7	59.2	43.2
FRTF24T-12N	1-1/2"	38	1 7/8"-12	1-1/2"	33.0	65.1	57.0	100.1	73.4	52.8
FRTF32T-16N	2"	50	2 1/2"-12	2"	45.0	71.4	73.0	111.3	83.8	60.7

* Pipe Thread NPT(N) or PT(R).

All dimensions are in millimeters unless otherwise specified. Dimensions are for reference only, subject to change.

Female Branch Tee

FBTF

SAE J514(070427)

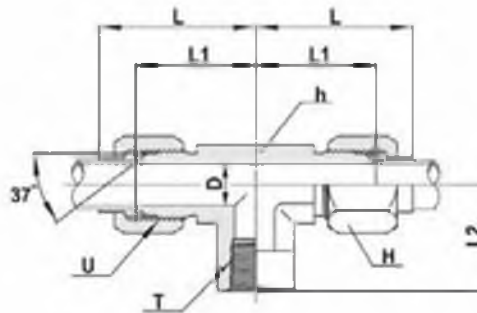

Part No.	Tube O.D.		U (UNF)	T (NPT)	D	h (HEX)	H (HEX)	L	L1	L2
	Inch	Metric								
FBTF2T-01N	1/8"	3	5/16"-24	1/8"	1.6	14.3	9.5	33.2	25.4	16.8
FBTF3T-01N	3/16"	4	3/8"-24	1/8"	3.2	14.3	11.0	35.8	26.2	16.8
FBTF4T-01N	1/4"	6	7/16"-20	1/8"	4.4	14.3	14.2	36.5	27.4	16.8
FBTF5T-01N	5/16"	8	1/2"-20	1/8"	6.0	14.3	16.0	37.8	27.4	16.8
FBTF8T-02N	3/8"	10	9/16"-18	1/4"	7.5	19.0	17.4	43.1	31.2	22.4
FBTF8T-03N	1/2"	12	3/4"-18	3/8"	9.9	22.2	22.2	48.8	36.1	25.9
FBTF10T-04N	5/8"	16	7/8"-14	1/2"	12.3	27.0	25.4	58.3	41.7	31.2
FBTF12T-06N	3/4"	18.20	1 1/16"-12	3/4"	15.5	33.3	32.0	63.5	48.0	34.5
FBTF14T-08N	7/8"	22	1 3/16"-12	3/4"	18.0	33.3	35.0	64.8	47.2	36.1
FBTF16T-08N	1"	25	1 5/16"-12	1"	21.5	41.3	38.0	74.1	55.1	41.1
FBTF20T-10N	1-1/4"	32	1 5/8"-12	1-1/4"	37.5	47.6	50.8	77.7	59.2	43.2
FBTF24T-12N	1-1/2"	38	1 7/8"-12	1-1/2"	33.0	65.1	57.0	100.1	73.4	52.8
FBTF32T-16N	2"	50	2 1/2"-12	2"	45.0	71.4	73.0	111.3	83.8	60.7

• Pipe Thread NPT(N) or PT(R).

All dimensions are in millimeters unless otherwise specified. Dimensions are for reference only, subject to change.

O-Ring Seal Male Connector.(PF)

FOMR

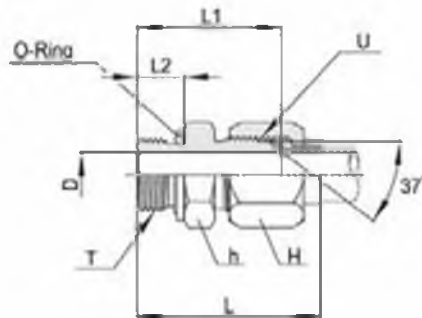

Part No.	Tube O.D.		U (UNF)	T (PF)	D	h (HEX)	H (HEX)	L	L1	L2
	Inch	Metric								
FOMR2T-01G	1/8"	3	5/16"-24	1/8"	1.6	11.1	9.5	35.3	27.5	8.0
FOMR3T-01G	3/16"	4	3/8"-24	1/8"	3.2	12.7	11.0	37.9	28.5	8.0
FOMR4T-01G	1/4"	6	7/16"-20	1/8"	4.4	14.2	14.2	39.3	30.2	8.0
FOMR5T-01G	5/16"	8	1/2"-20	1/8"	6.0	15.8	16.0	40.6	30.2	8.0
FOMR6T-02G	3/8"	10	9/16"-18	1/4"	7.5	17.4	17.4	46.9	35.0	12.0
FOMR8T-03G	1/2"	12	3/4"-16	3/8"	9.9	22.2	22.2	51.4	38.7	12.0
FOMR10T-04G	5/8"	16	7/8"-14	1/2"	12.3	25.4	25.4	61.1	44.5	14.0
FOMR12T-06G	3/4"	18,20	1 1/16"-12	3/4"	15.5	31.7	32.0	66.4	50.8	16.0
FOMR14T-08G	7/8"	22	1 3/16"-12	3/4"	18.0	34.9	35.0	69.0	51.4	16.0
FOMR16T-08G	1"	25	1 5/16"-12	1"	21.5	38.0	38.0	71.7	52.7	18.0
FOMR20T-10G	1-1/4"	32	1 5/8"-12	1-1/4"	37.5	42.8	50.8	78.5	60.0	20.0
FOMR24T-12G	1-1/2"	38	1 7/8"-12	1-1/2"	33.0	55.0	57.0	92.8	66.1	21.0
FOMR32T-16G	2"	50	2 1/2"-12	2"	45.0	70.0	73.0	108.0	80.5	25.0

All dimensions are in millimeters unless otherwise specified. Dimensions are for reference only, subject to change.

O-Ring Seal Male Connector.(UNF)

FOM

SAE J514(070120)

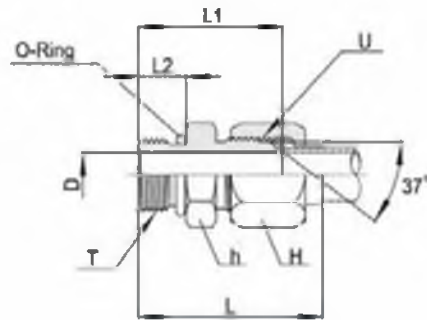

Part No.	Tube O.D.		U (UNF)	T (UNF)	D	h (HEX)	H (HEX)	L	L1	L2
	Inch	Metric								
FOM2T-02U	1/8"	3	5/16"-24	5/16"-24	1.8	11.1	9.5	34.7	26.9	7.5
FOM3T-03U	3/16"	4	3/8"-24	3/8"-24	3.2	12.7	11.0	37.3	27.9	7.5
FOM4T-04U	1/4"	6	7/16"-20	7/16"-20	4.4	14.2	14.2	40.3	31.2	9.1
FOM5T-05U	5/16"	8	1/2"-20	1/2"-20	6.0	15.8	16.0	41.6	31.2	9.1
FOM6T-06U	3/8"	10	9/16"-18	9/16"-18	7.5	17.4	17.4	44.9	33.0	9.9
FOM8T-08U	1/2"	12	3/4"-16	3/4"-16	9.9	22.2	22.2	50.3	37.6	11.1
FOM10T-10U	5/8"	16	7/8"-14	7/8"-14	12.3	25.4	25.4	59.8	43.2	12.7
FOM12T-12U	3/4"	18,20	1 1/16"-12	1 1/16"-12	15.5	31.7	32.0	65.5	50.0	15.1
FOM14T-14U	7/8"	22	1 3/16"-12	1 3/16"-12	18.0	34.9	35.0	68.1	50.5	15.1
FOM16T-16U	1"	25	1 5/16"-12	1 5/16"-12	21.5	38.1	38.0	70.8	51.8	15.1
FOM20T-20U	1-1/4"	32	1 5/8"-12	1 5/8"-12	37.5	47.6	50.8	73.6	55.1	15.1
FOM24T-24U	1-1/2"	38	1 7/8"-12	1 7/8"-12	33.0	53.9	57.0	86.9	60.2	15.1
FOM32T-32U	2"	50	2 1/2"-12	2 1/2"-12	45.0	69.8	73.0	98.1	70.6	15.1

All dimensions are in millimeters unless otherwise specified. Dimensions are for reference only, subject to change.

37° Flared Tube Fitting

SAE J514

O-Ring Seal Male Elbow.(UNF)

FOLM

SAE J514(070220)

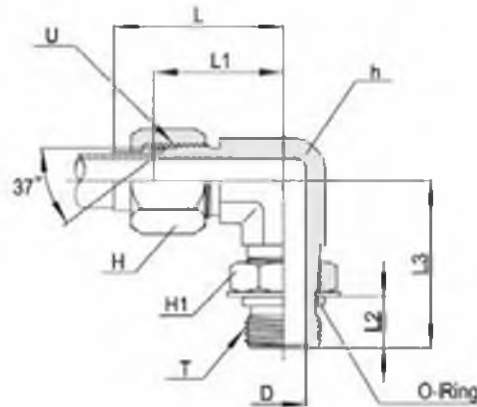

Part No.	Tube O.D.		U (UNF)	T (UNF)	D	h (HEX)	H (HEX)	H1 (HEX)	L	L1	L2	L3
	Inch	Metrc										
FOLM2T-02U	1/8"	3	5/16"-24	5/16"-24	1.6	11.1	9.5	14.2	27.4	19.6	8.4	23.9
FOLM3T-03U	3/16"	4	3/8"-24	3/8"-24	3.2	11.1	11.0	15.8	30.5	21.1	8.4	23.9
FOLM4T-04U	1/4"	6	7/16"-20	7/16"-20	4.4	11.1	14.2	17.4	31.7	22.6	9.8	26.2
FOLM5T-05U	5/16"	8	1/2"-20	1/2"-20	6.0	14.3	16.0	19.0	34.5	24.1	9.8	26.7
FOLM6T-06U	3/8"	10	9/16"-18	9/16"-18	7.5	14.3	17.4	20.6	38.8	26.9	9.9	31.8
FOLM8T-08U	1/2"	12	3/4"-16	3/4"-16	9.9	19.0	22.2	25.4	44.5	31.8	11.0	36.8
FOLM10T-10U	5/8"	16	7/8"-14	7/8"-14	12.3	22.2	25.4	28.5	53.4	38.8	12.5	43.2
FOLM12T-12U	3/4"	18,20	1 1/16"-12	1 1/16"-12	15.5	27.0	32.0	34.9	57.7	42.2	16.5	49.3
FOLM14T-14U	7/8"	22	1 3/16"-12	1 3/16"-12	18.0	33.3	35.0	38.1	63.3	45.7	16.5	50.8
FOLM16T-16U	1"	25	1 5/16"-12	1 5/16"-12	21.5	33.3	38.0	41.2	65.0	46.0	16.5	52.1
FOLM20T-20U	1-1/4"	32	1 5/8"-12	1 5/8"-12	37.5	41.3	50.8	47.6	70.8	52.3	16.5	57.2
FOLM24T-24U	1-1/2"	38	1 7/8"-12	1 7/8"-12	33.0	47.6	57.0	53.9	85.9	59.2	16.5	60.7
FOLM32T-32U	2"	50	2 1/2"-12	2 1/2"-12	45.0	63.5	73.0	68.8	105.2	77.7	16.5	73.4

All dimensions are in millimeters unless otherwise specified. Dimensions are for reference only, subject to change.

O-Ring Seal 45° Male Elbow.(UNF)

FOLMB

SAE J514(070320)

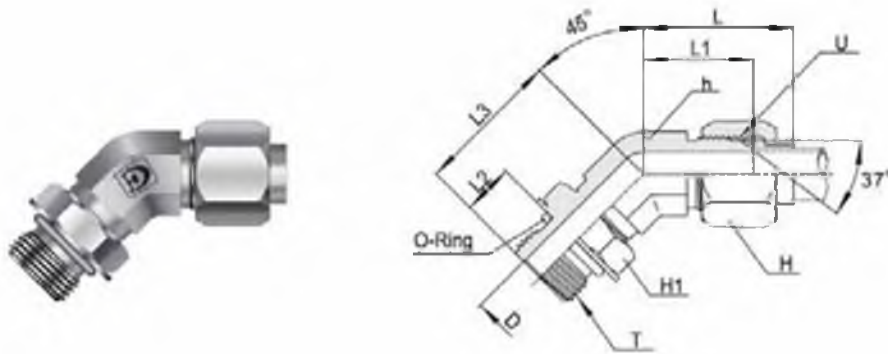

Part No.	Tube O.D.		U (UNF)	T (UNF)	D	h (HEX)	H (HEX)	H1 (HEX)	L	L1	L2	L3
	Inch	Metric										
FOLMB2T-02U	1/8"	3	5/16"-24	5/16"-24	1.6	11.1	9.5	14.2	25.3	17.5	8.4	23.9
FOLMB3T-03U	3/16"	4	3/8"-24	3/8"-24	3.2	11.1	11.0	15.8	26.9	17.5	8.4	23.9
FOLMB4T-04U	1/4"	6	7/16"-20	7/16"-20	4.4	11.1	14.2	17.4	27.4	18.3	9.8	23.9
FOLMB5T-05U	5/16"	8	1/2"-20	1/2"-20	6.0	14.3	16.0	19.0	30.0	19.6	9.8	25.4
FOLMB6T-06U	3/8"	10	9/16"-18	9/16"-18	7.5	14.3	17.4	20.6	33.0	21.1	9.9	28.4
FOLMB8T-08U	1/2"	12	3/4"-16	3/4"-16	9.9	19.0	22.2	25.4	37.6	24.9	11.0	32.5
FOLMB10T-10U	5/8"	16	7/8"-14	7/8"-14	12.3	22.2	25.4	28.5	44.8	28.2	12.5	36.6
FOLMB12T-12U	3/4"	18,20	1 1/16"-12	1 1/16"-12	15.5	27.0	32.0	34.9	48.0	32.5	18.5	43.9
FOLMB14T-14U	7/8"	22	1 3/16"-12	1 3/16"-12	18.0	33.3	35.0	38.1	54.4	36.8	18.5	45.7
FOLMB16T-16U	1"	25	1 5/16"-12	1 5/16"-12	21.5	33.3	38.0	41.2	58.3	37.3	16.5	47.2
FOLMB20T-20U	1-1/4"	32	1 5/8"-12	1 5/8"-12	37.5	41.3	50.8	47.6	58.9	40.4	16.5	48.5
FOLMB24T-24U	1-1/2"	38	1 7/8"-12	1 7/8"-12	33.0	47.6	57.0	53.9	71.9	45.2	16.5	48.5
FOLMB32T-32U	2"	50	2 1/2"-12	2 1/2"-12	45.0	63.5	73.0	69.8	83.9	56.4	16.5	47.2

All dimensions are in millimeters unless otherwise specified. Dimensions are for reference only, subject to change.

O-Ring Seal Branch Tee.(UNF)

FOBTM

SAE J514(070429)

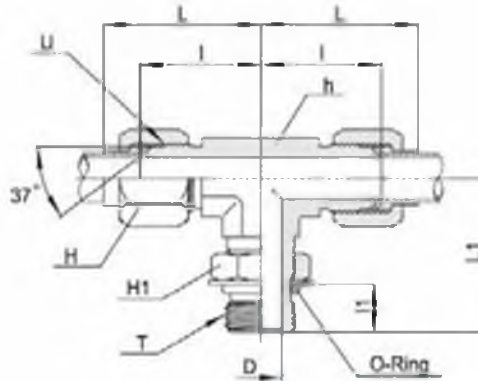

Part No.	Tube O.D.		U (UNF)	T (UNF)	D	h (HEX)	H (HEX)	H1 (HEX)	L	L1	I	I1
	Inch	Metric										
FOBTM2T-02U	1/8"	3	5/16"-24	5/16"-24	1.6	11.1	9.5	14.2	27.4	23.9	19.6	8.4
FOBTM3T-03U	3/16"	4	3/8"-24	3/8"-24	3.2	11.1	11.0	15.8	30.5	23.9	21.1	8.4
FOBTM4T-04U	1/4"	6	7/16"-20	7/16"-20	4.4	11.1	14.2	17.4	31.7	26.2	22.6	9.8
FOBTM5T-05U	5/16"	8	1/2"-20	1/2"-20	6.0	14.3	18.0	19.0	34.5	28.7	24.1	9.8
FOBTM6T-06U	3/8"	10	9/16"-18	9/16"-18	7.5	14.3	17.4	20.6	38.8	31.8	26.9	9.9
FOBTM8T-08U	1/2"	12	3/4"-16	3/4"-16	9.9	19.0	22.2	25.4	44.5	36.8	31.8	11.0
FOBTM10T-10U	5/8"	16	7/8"-14	7/8"-14	12.3	22.2	25.4	28.5	53.4	43.2	36.8	12.5
FOBTM12T-12U	3/4"	18,20	1 1/16"-12	1 1/16"-12	15.5	27.0	32.0	34.9	57.7	49.3	42.2	16.5
FOBTM14T-14U	7/8"	22	1 3/16"-12	1 3/16"-12	18.0	33.3	35.0	38.1	63.3	50.8	45.7	16.5
FOBTM16T-16U	1"	25	1 5/16"-12	1 5/16"-12	21.5	33.3	38.0	41.2	85.0	52.1	48.0	16.5
FOBTM20T-20U	1-1/4"	32	1 5/8"-12	1 5/8"-12	37.5	41.3	50.8	47.6	70.8	57.2	52.3	16.5
FOBTM24T-24U	1-1/2"	38	1 7/8"-12	1 7/8"-12	33.0	47.6	57.0	53.9	85.9	60.7	59.2	16.5
FOBTM32T-32U	2"	50	2 1/2"-12	2 1/2"-12	45.0	63.5	73.0	69.8	105.2	73.4	77.7	16.5

All dimensions are in millimeters unless otherwise specified. Dimensions are for reference only, subject to change.

O-Ring Seal Run Tee.(UNF)

FORTM

SAE J514(070428)

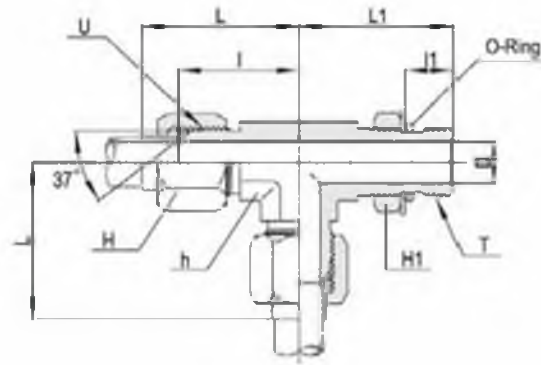

Part No.	Tube C.D.		U (UNF)	T (UNF)	D	h (HEX)	H (HEX)	H1 (HEX)	L	L1	I	II
	Inch	Metric										
FORTM2T-02U	1/8"	3	5/16"-24	5/16"-24	1.8	11.1	9.5	14.2	27.4	23.9	19.8	8.4
FORTM3T-03U	3/16"	4	3/8"-24	3/8"-24	3.2	11.1	11.0	15.8	30.5	23.9	21.1	8.4
FORTM4T-04U	1/4"	6	7/16"-20	7/16"-20	4.4	11.1	14.2	17.4	31.7	26.2	22.6	8.8
FORTM5T-05U	5/16"	8	1/2"-20	1/2"-20	6.0	14.3	16.0	19.0	34.5	28.7	24.1	9.8
FORTM6T-06U	3/8"	10	9/16"-18	9/16"-18	7.5	14.3	17.4	20.8	38.8	31.8	26.9	9.9
FORTM8T-08U	1/2"	12	3/4"-16	3/4"-16	9.9	19.0	22.2	25.4	44.5	36.8	31.8	11.0
FORTM10T-10U	5/8"	16	7/8"-14	7/8"-14	12.3	22.2	25.4	28.5	53.4	43.2	38.8	12.5
FORTM12T-12U	3/4"	18.20	1 1/16"-12	1 1/16"-12	15.5	27.0	32.0	34.9	57.7	49.3	42.2	16.5
FORTM14T-14U	7/8"	22	1 3/16"-12	1 3/16"-12	18.0	33.3	35.0	38.1	63.3	50.8	45.7	16.5
FORTM16T-16U	1"	25	1 5/16"-12	1 5/16"-12	21.5	33.3	38.0	41.2	65.0	52.1	46.0	16.5
FORTM20T-20U	1-1/4"	32	1 5/8"-12	1 5/8"-12	37.5	41.3	50.8	47.6	70.8	57.2	52.3	16.5
FORTM24T-24U	1-1/2"	38	1 7/8"-12	1 7/8"-12	33.0	47.6	57.0	53.9	85.9	60.7	59.2	16.5
FORTM32T-32U	2"	50	2 1/2"-12	2 1/2"-12	45.0	63.5	73.0	69.8	105.2	73.4	77.7	16.5

All dimensions are in millimeters unless otherwise specified. Dimensions are for reference only, subject to change.

Swivel Connector.

FSFMC

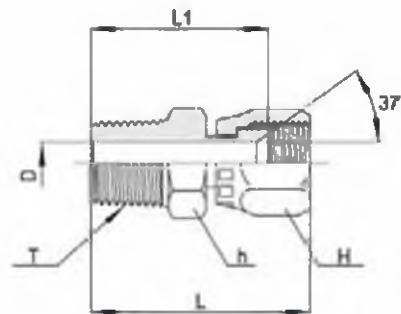

Part No.	Tube O.D.		U (UNF)	T (NPT)	D	h (HEX)	H (HEX)	L	L1
	Inch	Metnc							
FSFMC 2T-01N	1/8"	3	5/16"-24	1/8"	1.6	11.1	11.1	30.0	22.0
FSFMC 3T-01N	3/16"	4	3/8"-24	1/8"	3.2	11.1	12.7	32.0	23.5
FSFMC 4T-01N	1/4"	6	7/16"-20	1/8"	4.4	12.7	14.2	34.2	25.5
FSFMC 5T-01N	5/16"	8	1/2"-20	1/8"	6.0	14.2	16.0	35.0	25.5
FSFMC 6T-02N	3/8"	10	9/16"-18	1/4"	7.5	16.0	17.4	40.2	30.7
FSFMC 8T-03N	1/2"	12	3/4"-16	3/8"	9.9	21.0	22.2	42.7	32.0
FSFMC10T-04N	5/8"	16	7/8"-14	1/2"	12.3	23.8	25.4	51.3	38.6
FSFMC12T-06N	3/4"	18.20	1 1/16"-12	3/4"	15.5	29.0	32.0	54.5	40.2
FSFMC14T-08N	7/8"	22	1 3/16"-12	3/4"	18.0	32.0	35.0	56.0	41.2
FSFMC16T-08N	1"	25	1 5/16"-12	1"	21.5	36.0	38.0	63.7	48.6
FSFMC20T-10N	1-1/4"	32	1 5/8"-12	1-1/4"	37.5	46.0	50.8	68.9	53.0
FSFMC24T-12N	1-1/2"	38	1 7/8"-12	1-1/2"	33.0	50.0	57.0	77.6	59.0
FSFMC32T-16N	2"	50	2 1/2"-12	2"	45.0	66.7	73.0	92.9	69.1

* Pipe Thread NPT(N) or PT(R).

All dimensions are in millimeters unless otherwise specified. Dimensions are for reference only, subject to change.

O-Ring Seal Swivel Connector (UNF)

FSFOM

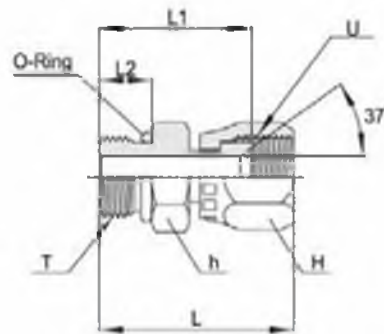

Part No.	Tube O.D.		U (UNF)	T (UNF)	h (HEX)	H (HEX)	L	L1	L1
	Inch	Metric							
FSFOM 2T-02U	1/8"	3	5/16"-24	5/16"-24	11.1	11.1	30.4	22.5	7.5
FSFOM 3T-02U	3/16"	4	3/8"-24	3/8"-24	12.7	12.7	31.0	22.7	7.5
FSFOM 4T-04U	1/4"	6	7/16"-20	7/16"-20	14.2	14.2	33.9	25.2	9.1
FSFOM 5T-05U	5/16"	8	1/2"-20	1/2"-20	15.8	15.8	35.7	26.2	9.1
FSFOM 6T-06U	3/8"	10	9/16"-18	9/16"-18	17.4	19.0	37.4	27.9	9.9
FSFOM 8T-08U	1/2"	12	3/4"-16	3/4"-16	22.2	22.2	41.6	30.8	11.1
FSFOM10T-10U	5/8"	16	7/8"-14	7/8"-14	25.4	27.0	47.6	34.9	12.7
FSFOM12T-12U	3/4"	18.20	1 1/16"-12	1 1/16"-12	31.8	32.0	54.4	40.1	15.1
FSFOM14T-14U	7/8"	22	1 3/16"-12	1 3/16"-12	34.9	34.9	55.6	40.9	15.1
FSFOM16T-16U	1"	25	1 5/16"-12	1 5/16"-12	38.1	38.1	56.8	41.7	15.1
FSFOM20T-20U	1-1/4"	32	1 5/8"-12	1 5/8"-12	47.6	50.8	63.2	47.3	15.1
FSFOM24T-24U	1-1/2"	38	1 7/8"-12	1 7/8"-12	54.0	60.0	71.3	52.7	15.1
FSFOM32T-32U	2"	50	2 1/2"-12	2 1/2"-12	70.0	73.0	72.5	58.7	15.1

All dimensions are in millimeters unless otherwise specified. Dimensions are for reference only, subject to change.

Swivel Female Connector.

FSFFC

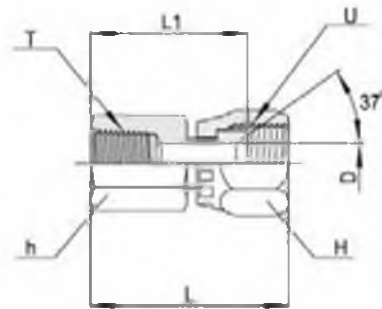

Part No	Tube O.D.		U (UNF)	T (NPT)	D	h (HEX)	H (HEX)	L	L1
	Inch	Metric							
FSFFC 2T-01N	1/8"	3	5/16"-24	1/8"	1.6	14.2	11.1	36.1	28.2
FSFFC 3T-01N	3/16"	4	3/8"-24	1/8"	3.2	14.2	12.7	37.3	29.0
FSFFC 4T-01N	1/4"	6	7/16"-20	1/8"	4.4	14.2	14.2	39.7	31.0
FSFFC 5T-01N	5/16"	8	1/2"-20	1/8"	6.0	14.2	16.0	40.5	31.0
FSFFC 6T-02N	3/8"	10	9/16"-18	1/4"	7.5	19.0	17.4	45.8	36.3
FSFFC 8T-03N	1/2"	12	3/4"-16	3/8"	9.9	22.2	22.2	47.0	38.9
FSFFC 10T-04N	5/8"	16	7/8"-14	1/2"	12.3	29.0	25.4	51.6	48.0
FSFFC 12T-06N	3/4"	18.20	1 1/16"-12	3/4"	15.5	35.0	32.0	66.6	52.3
FSFFC 14T-08N	7/8"	22	1 3/16"-12	3/4"	18.0	35.0	35.0	87.8	53.1
FSFFC 16T-08N	1"	25	1 5/16"-12	1"	21.5	41.0	38.0	73.5	58.4
FSFFC 20T-10N	1-1/4"	32	1 5/8"-12	1-1/4"	37.5	50.8	50.8	78.1	62.2
FSFFC 24T-12N	1-1/2"	38	1 7/8"-12	1-1/2"	33.0	60.0	57.0	86.7	66.1
FSFFC 32T-16N	2"	50	2 1/2"-12	2"	45.0	73.0	73.0	89.3	65.5

All dimensions are in millimeters unless otherwise specified. Dimensions are for reference only, subject to change.

37° Flared Tube Fitting

SAE J514

Swivel Elbow.

FSL

SAE J514(070221)

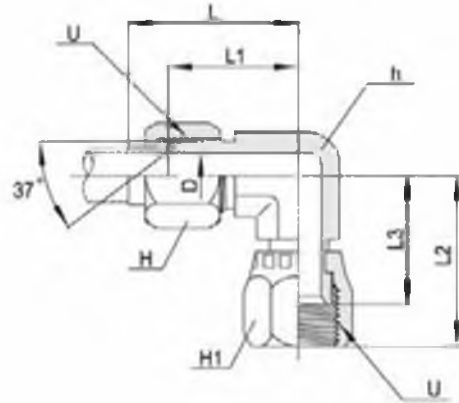

Part No.	Tube O.D.		U (UNF)	D	h (HEX)	H (HEX)	H1 (HEX)	L	L1	L2	L3
	Inch	Metric									
FSL-2T	1/8"	3	5/16"-24	1.6	11.1	9.5	11.1	27.4	19.6	24.6	16.7
FSL-3T	3/16"	4	3/8"-24	3.2	11.1	11.0	12.7	30.5	21.1	25.4	17.1
FSL-4T	1/4"	6	7/16"-20	4.4	11.1	14.2	14.2	31.7	22.6	25.4	16.7
FSL-5T	5/16"	8	1/2"-20	6.0	14.3	16.0	16.8	34.5	24.1	26.9	17.4
FSL-6T	3/8"	10	9/16"-18	7.5	14.3	17.4	17.4	38.8	26.9	31.8	22.3
FSL-8T	1/2"	12	3/4"-16	9.9	19.0	22.2	22.2	44.5	31.8	35.1	24.4
FSL-10T	5/8"	16	7/8"-14	12.3	22.2	25.4	25.4	53.4	38.8	41.1	28.4
FSL-12T	3/4"	18,20	1 1/16"-12	15.5	27.0	32.0	31.7	57.7	42.2	44.4	30.1
FSL-14T	7/8"	22	1 3/16"-12	19.0	33.3	35.0	34.9	63.3	45.7	45.2	30.5
FSL-16T	1"	25	1 5/16"-12	21.5	33.3	38.0	38.1	65.0	46.0	50.8	35.7
FSL-20T	1-1/4"	32	1 5/8"-12	37.5	41.3	50.8	50.8	70.8	52.3	58.7	42.8
FSL-24T	1-1/2"	38	1 7/8"-12	33.0	47.6	57.1	57.1	85.9	59.2	65.8	47.2
FSL-32T	2"	50	2 1/2"-12	45.0	63.5	73.0	69.8	105.2	77.7	85.9	62.1

All dimensions are in millimeters unless otherwise specified. Dimensions are for reference only, subject to change.

37° Flared Tube Fitting

SAE J514

Swivel Run Tee.

FSRT

SAE J514(070432)

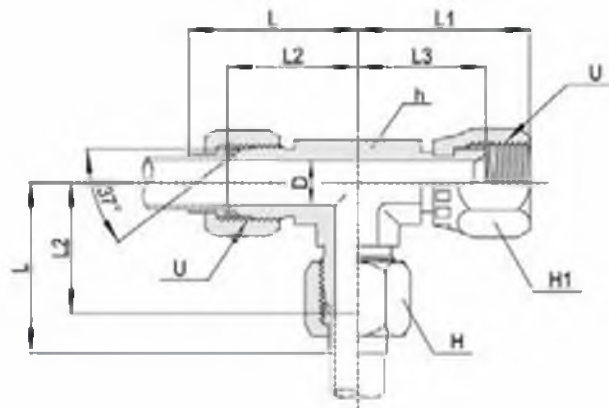

Part No.	Tube O.D.		U (UNF)	D	h (HEX)	H (HEX)	H1 (HEX)	L	L1	L2	L3
	Inch	Metric									
FSRT-2T	1/8"	3	5/16"-24	1.6	11.1	9.5	11.1	27.4	24.6	19.8	16.7
FSRT-3T	3/16"	4	3/8"-24	3.2	11.1	11.0	12.7	30.5	25.4	21.1	17.1
FSRT-4T	1/4"	6	7/16"-20	4.4	11.1	14.2	14.2	31.7	25.4	22.6	16.7
FSRT-5T	5/16"	8	1/2"-20	6.0	14.3	16.0	15.8	34.5	26.9	24.1	17.4
FSRT-6T	3/8"	10	9/16"-18	7.5	14.3	17.4	17.4	38.8	31.8	26.9	22.3
FSRT-8T	1/2"	12	3/4"-16	9.9	19.0	22.2	22.2	44.5	35.1	31.8	24.4
FSRT-10T	5/8"	16	7/8"-14	12.3	22.2	25.4	25.4	53.4	41.1	36.8	28.4
FSRT-12T	3/4"	18,20	1 1/16"-12	15.5	27.0	32.0	31.7	57.7	44.4	42.2	30.1
FSRT-14T	7/8"	22	1 3/16"-12	18.0	33.3	35.0	34.9	63.3	45.2	45.7	30.5
FSRT-16T	1"	25	1 5/16"-12	21.5	33.3	38.0	38.1	65.0	50.8	46.0	35.7
FSRT-20T	1-1/4"	32	1 5/8"-12	37.5	41.3	50.8	50.8	70.8	58.7	52.3	42.8
FSRT-24T	1-1/2"	38	1 7/8"-12	33.0	47.6	57.1	57.0	85.9	65.8	59.2	47.2
FSRT-32T	2"	50	2 1/2"-12	45.0	63.5	73.0	69.8	105.2	85.9	77.7	62.1

All dimensions are in millimeters unless otherwise specified. Dimensions are for reference only, subject to change.

Swivel Branch Tee.

FSBT

SAE J514(070433)

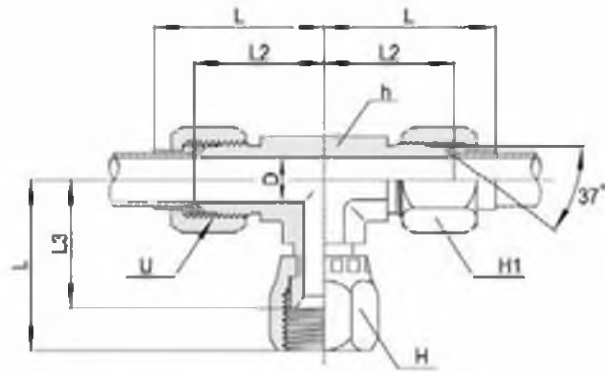
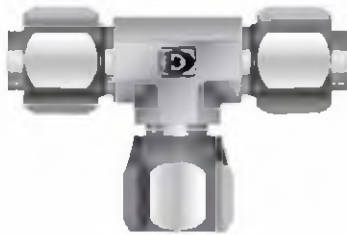

Part No.	Tube O.D.		U (UNF)	D	h (HEX)	H (HEX)	H1 (HEX)	L	L1	L2	L3
	Inch	Metric									
FSBT-2T	1/8"	3	5/16"-24	1.8	11.1	9.5	11.1	27.4	24.8	19.8	18.7
FSBT-3T	3/16"	4	3/8"-24	3.2	11.1	11.0	12.7	30.5	25.4	21.1	17.1
FSBT-4T	1/4"	6	7/16"-20	4.4	11.1	14.2	14.2	31.7	25.4	22.8	18.7
FSBT-5T	5/16"	8	1/2"-20	6.0	14.3	16.0	15.8	34.5	28.9	24.1	17.4
FSBT-6T	3/8"	10	9/16"-18	7.5	14.3	17.4	17.4	38.8	31.8	26.9	22.3
FSBT-8T	1/2"	12	3/4"-16	9.9	19.0	22.2	22.2	44.5	35.1	31.8	24.4
FSBT-10T	5/8"	18	7/8"-14	12.3	22.2	25.4	25.4	53.4	41.1	36.8	28.4
FSBT-12T	3/4"	18.20	1 1/16"-12	15.5	27.0	32.0	31.7	57.7	44.4	42.2	30.1
FSBT-14T	7/8"	22	1 3/16"-12	18.0	33.3	35.0	34.9	63.3	45.2	45.7	30.5
FSBT-16T	1"	25	1 5/16"-12	21.5	33.3	38.0	38.1	65.0	50.8	46.0	35.7
FSBT-20T	1-1/4"	32	1 5/8"-12	37.5	41.3	50.8	50.8	70.8	58.7	52.3	42.8
FSBT-24T	1-1/2"	38	1 7/8"-12	33.0	47.6	57.1	57.0	85.9	65.8	59.2	47.2
FSBT-32T	2"	50	2 1/2"-12	45.0	63.5	73.0	69.8	105.2	85.9	77.7	62.1

All dimensions are in millimeters unless otherwise specified. Dimensions are for reference only, subject to change.

37° Flared Tube Fitting

SAE J514

Nut

FN

SAE J514(070110)

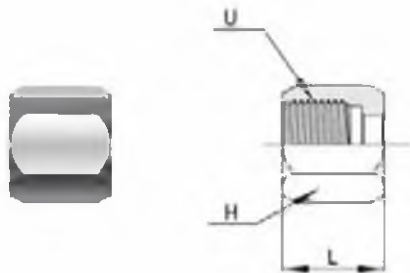

Sleeve

FS

SAE J514(070115)

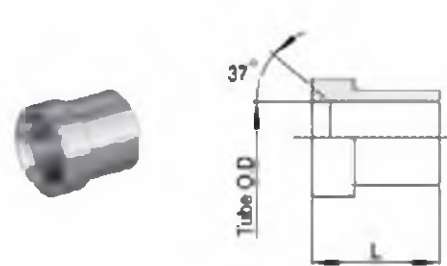

Part No.	Tube O.D.		U (UNF)	H (HEX)	L
	Inch	Metric			
FN-2T	1/8"	3	5/16"-24	9.5	14.0
FN-3T	3/16"	4	3/8"-24	11.1	15.5
FN-4T	1/4"	6	7/16"-20	14.2	15.8
FN-5T	5/16"	8	1/2"-20	15.8	17.3
FN-6T	3/8"	10	9/16"-18	17.4	18.5
FN-8T	1/2"	12	3/4"-16	22.2	21.6
FN-10T	5/8"	18	7/8"-14	25.4	24.9
FN-12T	3/4"	18.20	1 1/16"-12	31.7	26.2
FN-14T	7/8"	22	1 3/16"-12	34.9	27.7
FN-16T	1"	25	1 5/16"-12	38.1	28.7
FN-20T	1-1/4"	32	1 5/8"-12	50.8	31.2
FN-24T	1-1/2"	38	1 7/8"-12	57.1	36.1
FN-32T	2"	50	2 1/2"-12	73.0	44.5

Part No.	Tube O.D.		L
	Inch	Metric	
FS-2T	1/8"	3	8.6
FS-3T	3/16"	4	8.6
FS-4T	1/4"	6	10.4
FS-5T	5/16"	8	11.2
FS-6T	3/8"	10	12.7
FS-8T	1/2"	12	14.2
FS-10T	5/8"	16	18.8
FS-12T	3/4"	18.20	17.3
FS-14T	7/8"	22	19.3
FS-16T	1"	25	19.8
FS-20T	1-1/4"	32	23.1
FS-24T	1-1/2"	38	28.4
FS-32T	2"	50	30.2

All dimensions are in millimeters unless otherwise specified. Dimensions are for reference only, subject to change.

37° Flared Tube Fitting

SAE J514

Plug

FP

SAE J514(070109)

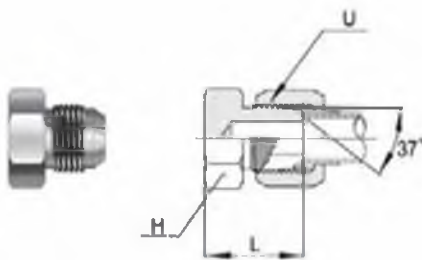

Plug Cap

FPC

SAE J514(070112)

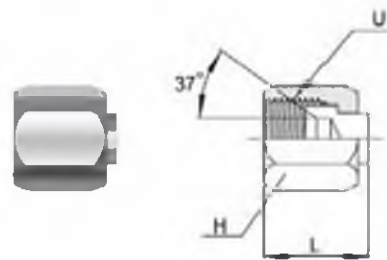

Part No.	Tube O.D.		U (UNF)	H (HEX)	L
	Inch	Metric			
FP-2T	1/8"	3	5/16"-24	11.1	17.8
FP-3T	3/16"	4	3/8"-24	11.1	18.5
FP-4T	1/4"	6	7/16"-20	12.7	20.3
FP-5T	5/16"	8	1/2"-20	14.2	20.3
FP-6T	3/8"	10	9/16"-18	15.8	21.3
FP-8T	1/2"	12	3/4"-16	20.6	23.9
FP-10T	5/8"	16	7/8"-14	20.6	27.9
FP-12T	3/4"	18.20	1 1/16"-12	28.5	32.5
FP-14T	7/8"	22	1 3/16"-12	31.7	33.3
FP-16T	1"	25	1 5/16"-12	34.9	33.8
FP-20T	1-1/4"	32	1 5/8"-12	42.8	36.8
FP-24T	1-1/2"	38	1 7/8"-12	50.8	41.9
FP-32T	2"	50	2 1/2"-12	66.6	52.1

Part No.	Tube O.D.		U (UNF)	H (HEX)	L
	Inch	Metric			
FPC-2T	1/8"	3	5/16"-24	9.5	13.7
FPC-3T	3/16"	4	3/8"-24	11.1	15.2
FPC-4T	1/4"	6	7/16"-20	14.2	15.5
FPC-5T	5/16"	8	1/2"-20	15.8	17.0
FPC-6T	3/8"	10	9/16"-18	17.4	18.3
FPC-8T	1/2"	12	3/4"-16	22.2	21.3
FPC-10T	5/8"	16	7/8"-14	25.4	24.6
FPC-12T	3/4"	18.20	1 1/16"-12	31.7	25.9
FPC-14T	7/8"	22	1 3/16"-12	34.9	27.4
FPC-16T	1"	25	1 5/16"-12	38.1	28.4
FPC-20T	1-1/4"	32	1 5/8"-12	50.8	31.0
FPC-24T	1-1/2"	38	1 7/8"-12	57.1	35.8
FPC-32T	2"	50	2 1/2"-12	73.0	44.2

All dimensions are in millimeters unless otherwise specified. Dimensions are for reference only, subject to change.

37° Flared Tube Fitting

SAE J514

Tube End Reducer

FTER

SAE J514(070123)

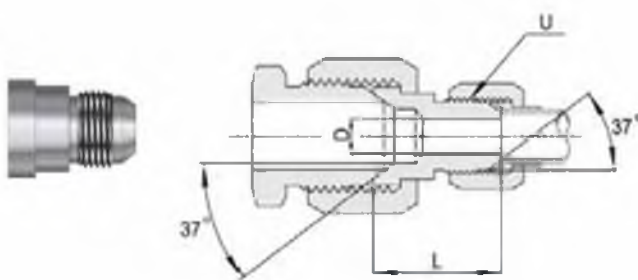

Bulkhead Lock Nut

FLN

SAE J514(070118)

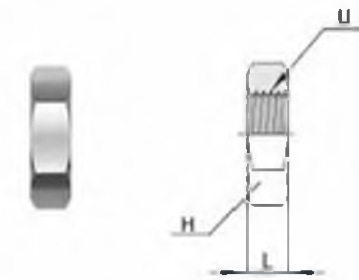

Part No.	Reducing Tube O.D.	U (UNF)	D	L
FTER8T-4T	3/8" x 1/4"	7/16"-20	4.4	24.6
FTER8T-4T	1/2" x 1/4"	7/16"-20	4.4	25.4
FTER8T-6T	1/2" x 3/8"	9/16"-18	7.5	25.4
FTER10T-4T	5/8" x 1/4"	7/16"-20	4.4	26.2
FTER10T-8T	5/8" x 3/8"	9/16"-18	7.5	26.2
FTER12T-4T	3/4" x 1/4"	7/16"-20	4.4	27.7
FTER12T-8T	3/4" x 3/8"	9/16"-18	7.5	27.7
FTER12T-8T	3/4" x 1/2"	3/4"-18	10.0	30.2
FTER16T-12T	1" x 3/4"	1-1/16"-12	15.5	37.3
FTER20T-12T	1-1/4" x 3/4"	1-1/16"-12	15.5	38.3
FTER20T-18T	1-1/4" x 1"	1-5/16"-12	21.5	40.3
FTER24T-20T	1-1/2" x 1-1/4"	1-5/8"-12	27.5	42.9

Part No.	Tube O.D.		U (UNF)	H (HEX)	L
	Inch	Metric			
FLN-2T	1/8"	3	5/16"-24	14.2	5.6
FLN-3T	3/16"	4	3/8"-24	15.8	5.6
FLN-4T	1/4"	6	7/16"-20	17.4	6.4
FLN-5T	5/16"	8	1/2"-20	19.0	6.4
FLN-8T	3/8"	10	9/16"-18	20.8	8.9
FLN-8T	1/2"	12	3/4"-16	25.4	7.9
FLN-10T	5/8"	18	7/8"-14	28.5	9.1
FLN-12T	3/4"	18,20	1-1/16"-12	34.9	10.4
FLN-14T	7/8"	22	1-3/16"-12	38.1	10.4
FLN-18T	1"	25	1-5/16"-12	41.2	10.4
FLN-20T	1-1/4"	32	1-5/8"-12	47.6	10.4
FLN-24T	1-1/2"	38	1-7/8"-12	53.9	10.4
FLN-32T	2"	50	2-1/2"-12	69.8	10.4

All dimensions are in millimeters unless otherwise specified. Dimensions are for reference only, subject to change.

По вопросам продаж и поддержки обращайтесь:

Архангельск +7 (8182) 45-71-35	Калининград +7 (4012) 72-21-36	Новороссийск +7 (8617) 30-82-64	Сочи +7 (862) 279-22-65
Астана +7 (7172) 69-68-15	Калуга +7 (4842) 33-35-03	Новосибирск +7 (383) 235-95-48	Ставрополь +7 (8652) 57-76-63
Астрахань +7 (8512) 99-46-80	Кемерово +7 (3842) 21-56-70	Омск +7 (381) 299-16-70	Сургут +7 (3462) 77-96-35
Барнаул +7 (3852) 37-96-76	Киров +7 (8332) 20-58-70	Орел +7 (4862) 22-23-86	Сызрань +7 (8464) 33-50-64
Белгород +7 (4722) 20-58-80	Краснодар +7 (861) 238-86-59	Оренбург +7 (3532) 48-64-35	Сыктывкар +7 (8212) 28-83-02
Брянск +7 (4832) 32-17-25	Красноярск +7 (391) 989-82-67	Пенза +7 (8412) 23-52-98	Тверь +7 (4822) 39-50-56
Владивосток +7 (4232) 49-26-85	Курск +7 (4712) 23-80-45	Первоуральск +7 (3439) 26-01-18	Томск +7 (3822) 48-95-05
Владимир +7 (4922) 49-51-33	Липецк +7 (4742) 20-01-75	Пермь +7 (342) 233-81-65	Тула +7 (4872) 44-05-30
Волгоград +7 (8442) 45-94-42	Магнитогорск +7 (3519) 51-02-81	Ростов-на-Дону +7 (863) 309-14-65	Тюмень +7 (3452) 56-94-75
Воронеж +7 (4732) 12-26-70	Москва +7 (499) 404-24-72	Рязань +7 (4912) 77-61-95	Ульяновск +7 (8422) 42-51-95
Екатеринбург +7 (343) 302-14-75	Мурманск +7 (8152) 65-52-70	Самара +7 (846) 219-28-25	Уфа +7 (347) 258-82-65
Иваново +7 (4932) 70-02-95	Наб.Челны +7 (8552) 91-01-32	Санкт-Петербург +7 (812) 660-57-09	Хабаровск +7 (421) 292-95-69
Ижевск +7 (3412) 20-90-75	Ниж.Новгород +7 (831) 200-34-65	Саранск +7 (8342) 22-95-16	Чебоксары +7 (8352) 28-50-89
Иркутск +7 (3952) 56-24-09	Нижневартовск +7 (3466) 48-22-23	Саратов +7 (845) 239-86-35	Челябинск +7 (351) 277-89-65
Йошкар-Ола +7 (8362) 38-66-61	Нижнекамск +7 (8555) 24-47-85	Смоленск +7 (4812) 51-55-32	Череповец +7 (8202) 49-07-18
Казань +7 (843) 207-19-05			Ярославль +7 (4852) 67-02-35

сайт: hylok.pro-solution.ru | эл. почта: hky@pro-solution.ru

телефон: 8 800 511 88 70